

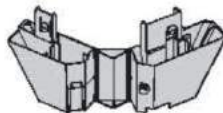

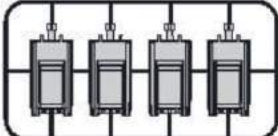

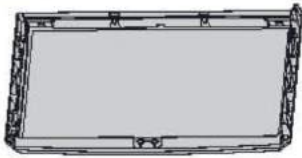

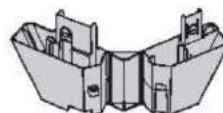

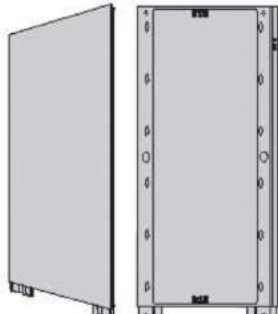
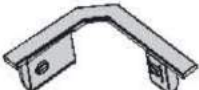
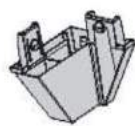
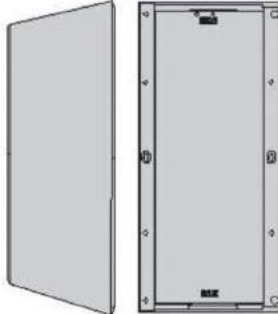
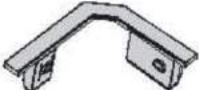
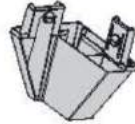
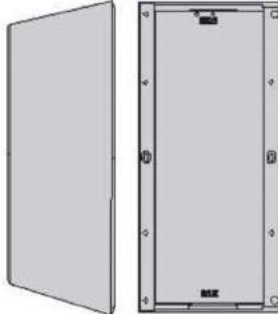

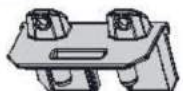
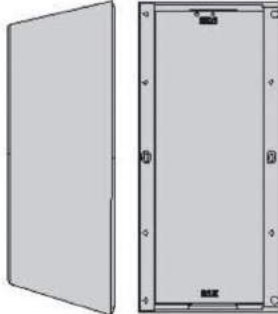

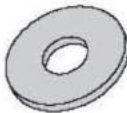
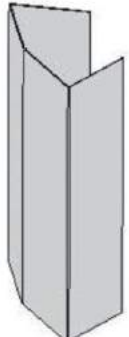
STILO

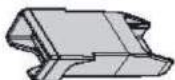
cm 68x39x173 h

IT Istruzioni per il montaggio DE Assembly instruction DE Montageanleitungen FR Instructions pour le montage ES Instrucción para el montaje NL Instructies voor de montage TR Montaj talimatları GR Οδηγίες συναρμολόγησης LT Instrukcijos za montaz RO Instrucțiuni de montaj CZ Návod na montáž PL Instrukcja montażu PT Instruções de montagem

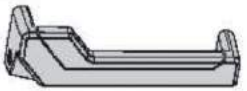
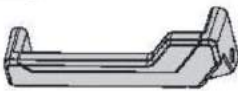
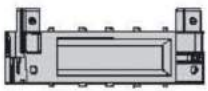

<p>3x E1E</p> 	<p>A2E</p> 	<p>3x E2E</p> 
<p>2x A/C1E</p> 	<p>A3E</p> 	<p>4x B1E</p> 
<p>C4E</p> 	<p>A4E</p> 	<p>4x D1E</p> 
<p>C5E</p> 	<p>A5E</p> 	<p>4x D1E</p> 
<p>C3E</p> 	<p>2x A/C3E</p> 	<p>4x D1E</p> 
<p>C2E</p> 	<p>2x</p> 	<p>x2</p> 
<p>2x D2E</p> 	<p>2x</p> 	<p>2x B8E</p> 
<p>4x [4,2x22 mm]</p> 	<p>10x [3,9x13 mm]</p> 	<p>2x B4E</p> 
<p>2x D4E</p> 	<p>2x D3E</p> 	<p>B3E</p> 
<p>D7E</p> 	<p>D8E</p> 	<p>2x B2E</p> 



IT Conservare il manuale d'uso per referenze future in prossimità del prodotto. Prima di iniziare l'assemblaggio leggere attentamente le avvertenze. **GB** Keep this instruction manual with the product for future reference. Read the instructions carefully before assembly. **DE** Bewahren Sie das Benutzerhandbuch in der Nähe des Produkts auf, damit Sie später jederzeit nachschlagen können. Lesen Sie vor der Montage die Anweisungen aufmerksam durch. **FR** Conserver le manuel d'utilisation à proximité du produit pour de futures références. Lire attentivement la notice avant de commencer l'assemblage. **ES** Guarde el manual de uso para futuras consultas acerca del producto. Antes de empezar el montaje, lea detenidamente las advertencias. **NL** Bewaar de handleiding in nabijheid van het product voor toekomstige raadpleging. Lees deze voorschriften aandachtig alvorens met de montage te beginnen. **TR** Kullanıcı kılavuzunu ürüne yakın bir yerde saklayın. Montajı başlamadan önce etiketleri dikkatle okuyun. **GR** Φυλάξτε αυτό το εγχειρίδιο χρήσης κοντά στο προϊόν για μελλοντικές χρήσεις. Πριν ξεκινήσετε την συναρμολόγηση διαβάστε προσεκτικά τις προειδοποιήσεις ασφαλείας. **RU** Храните руководство пользователя поблизости от изделия для дальнейшего к нему обращения. Перед тем, как приступить к сборке, внимательно ознакомьтесь с предупреждениями. **RO** Păstrați manualul de utilizare în apropierea produsului pentru consultări ulterioare. Înainte de a începe asamblarea citiți cu atenție avertismentele. **CZ** Uchovejte tento návod pro jeho případné další použití. Před montáží si pečlivě pročtěte instrukce. **PL** Przechowywać instrukcję obsługi w pobliżu produktu do przyszłych konsultacji. Przed rozpoczęciem montażu przeczytać uważnie pouczenia. **PT** Guarde o manual de uso para consultas futuras na proximidade do produto. Antes de iniciar a montagem, leia os avisos com atenção.

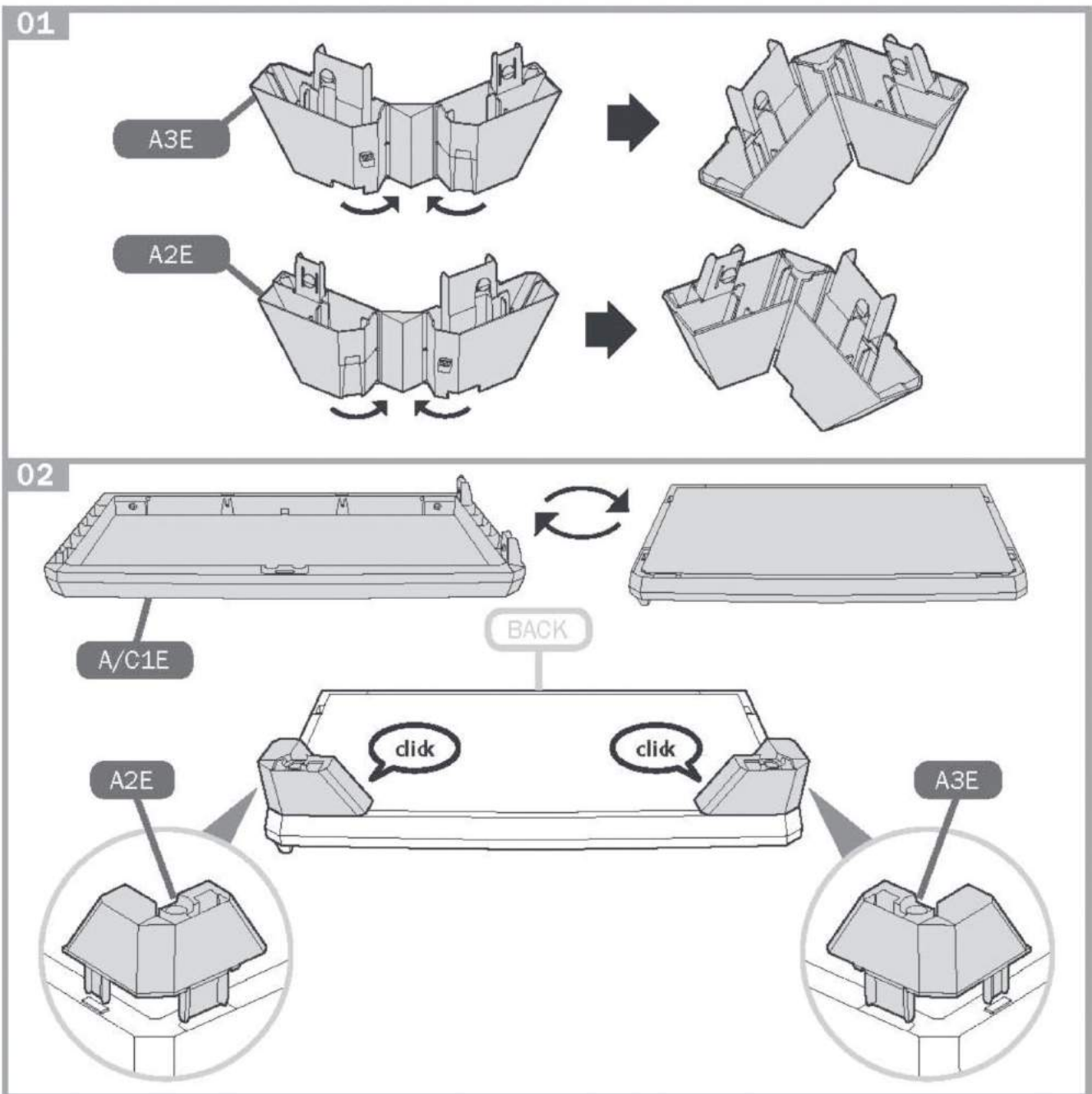

03

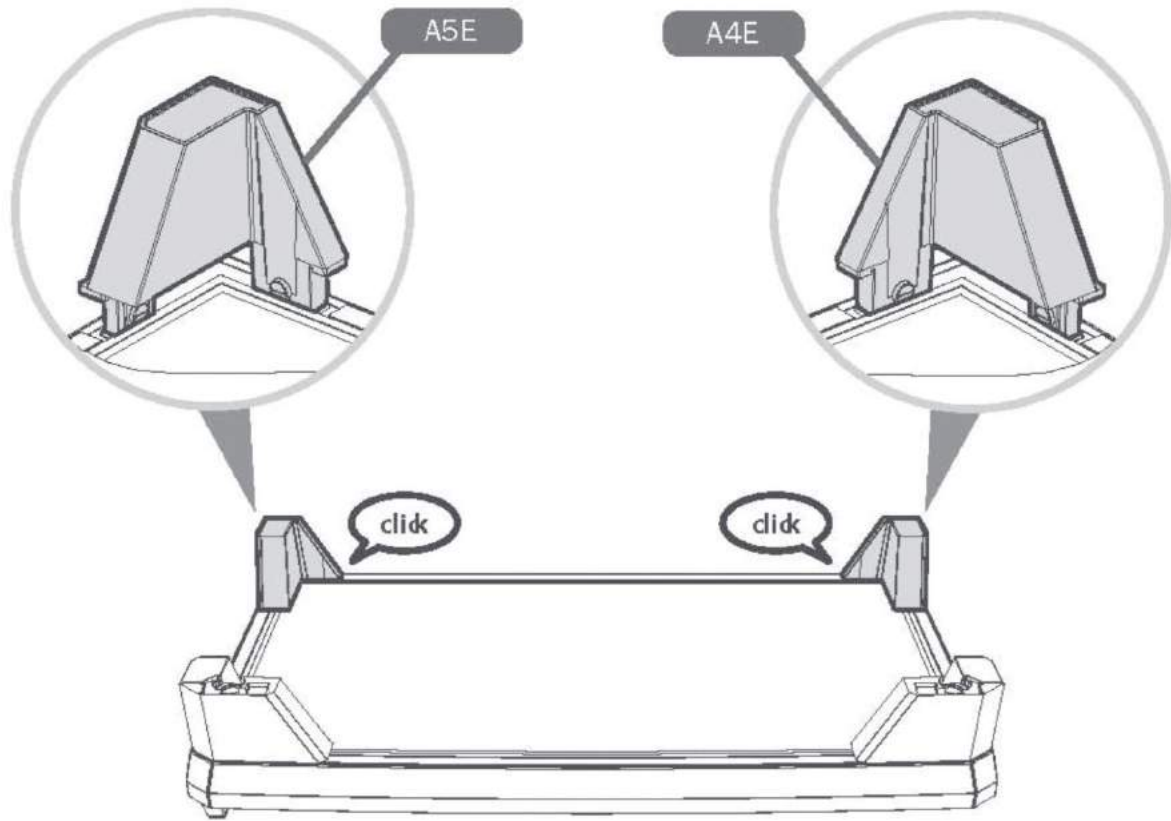

04

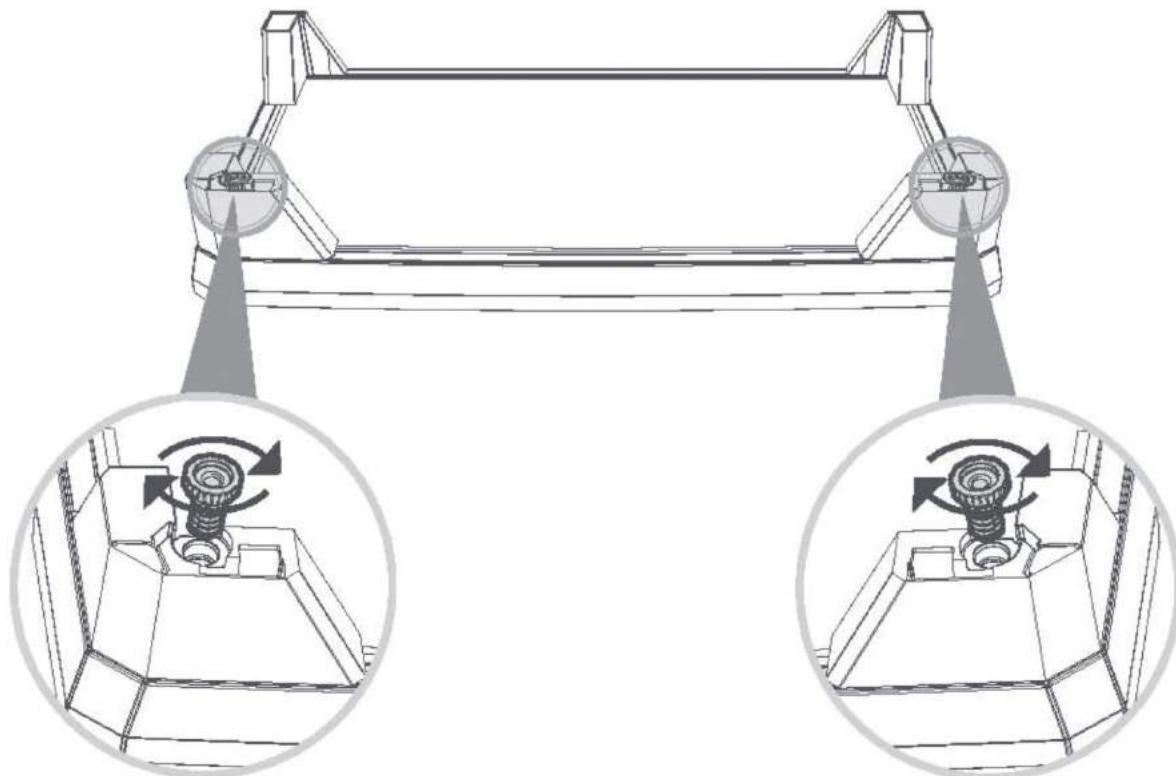

05

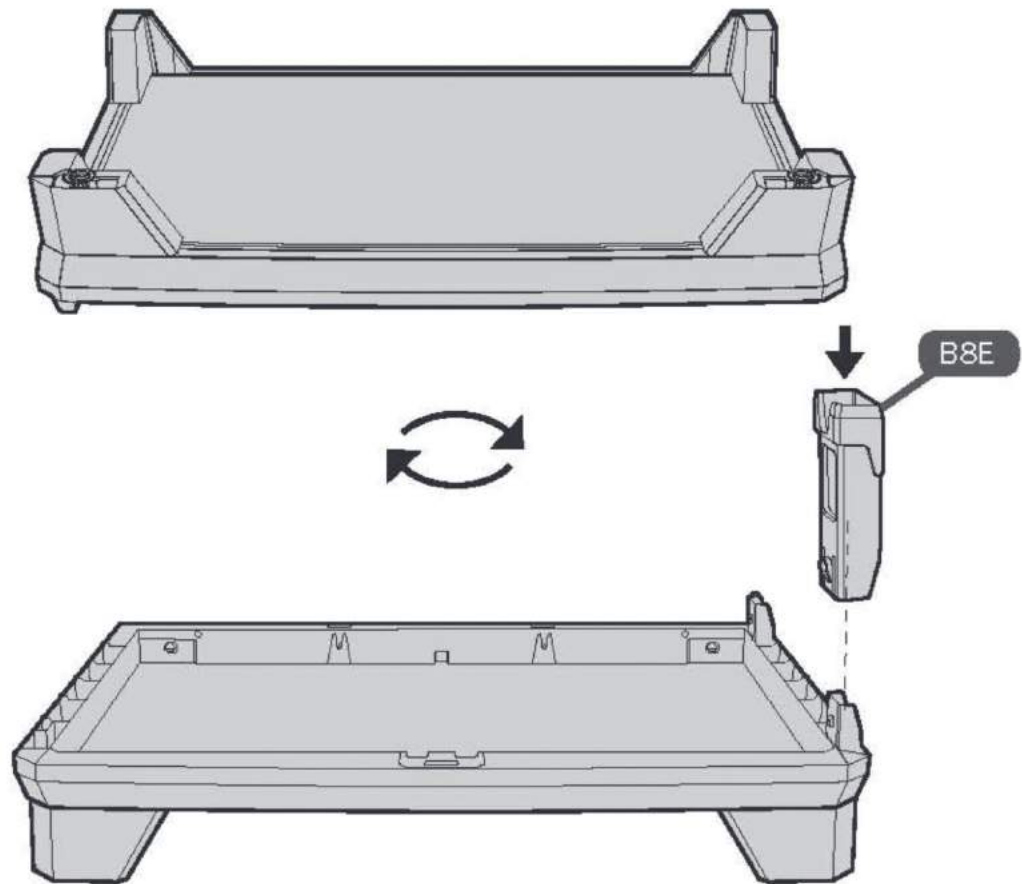

06

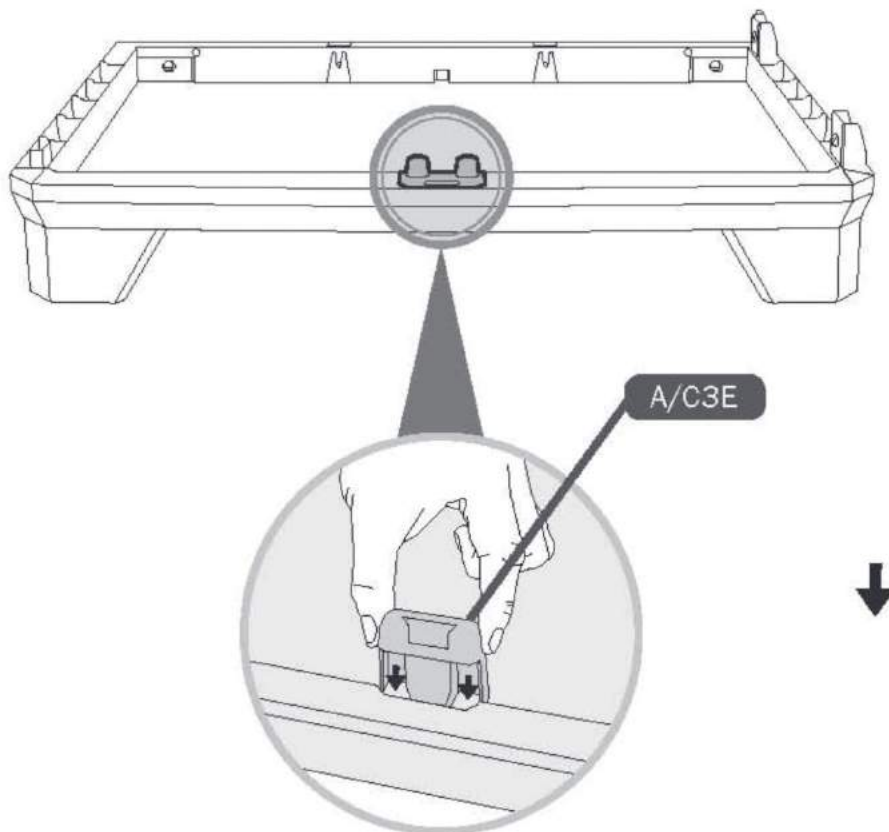

07

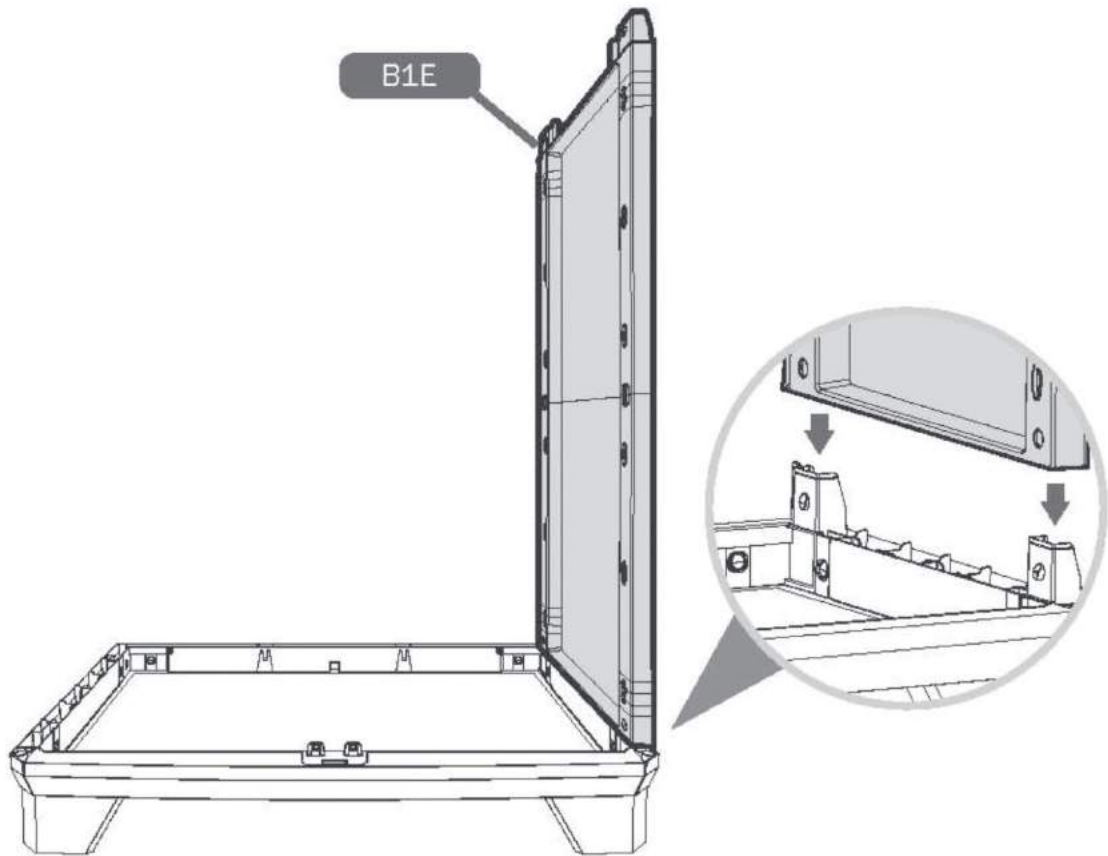

08

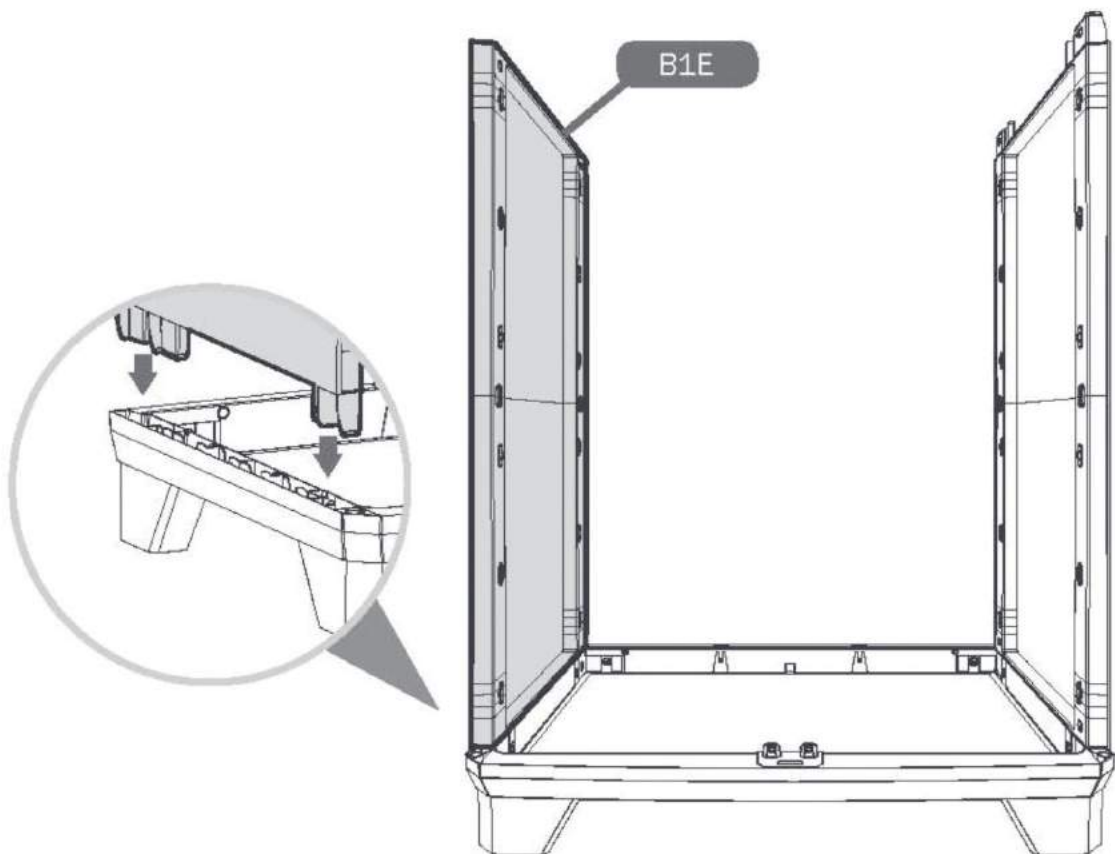

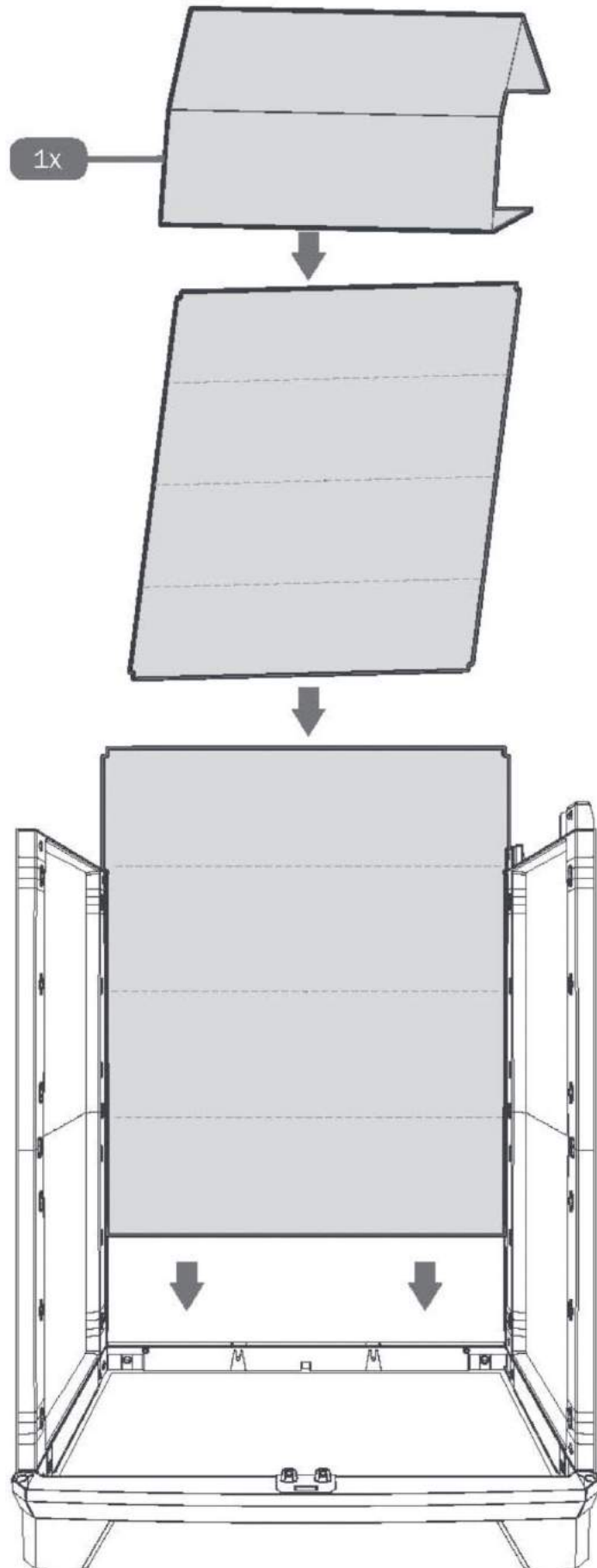

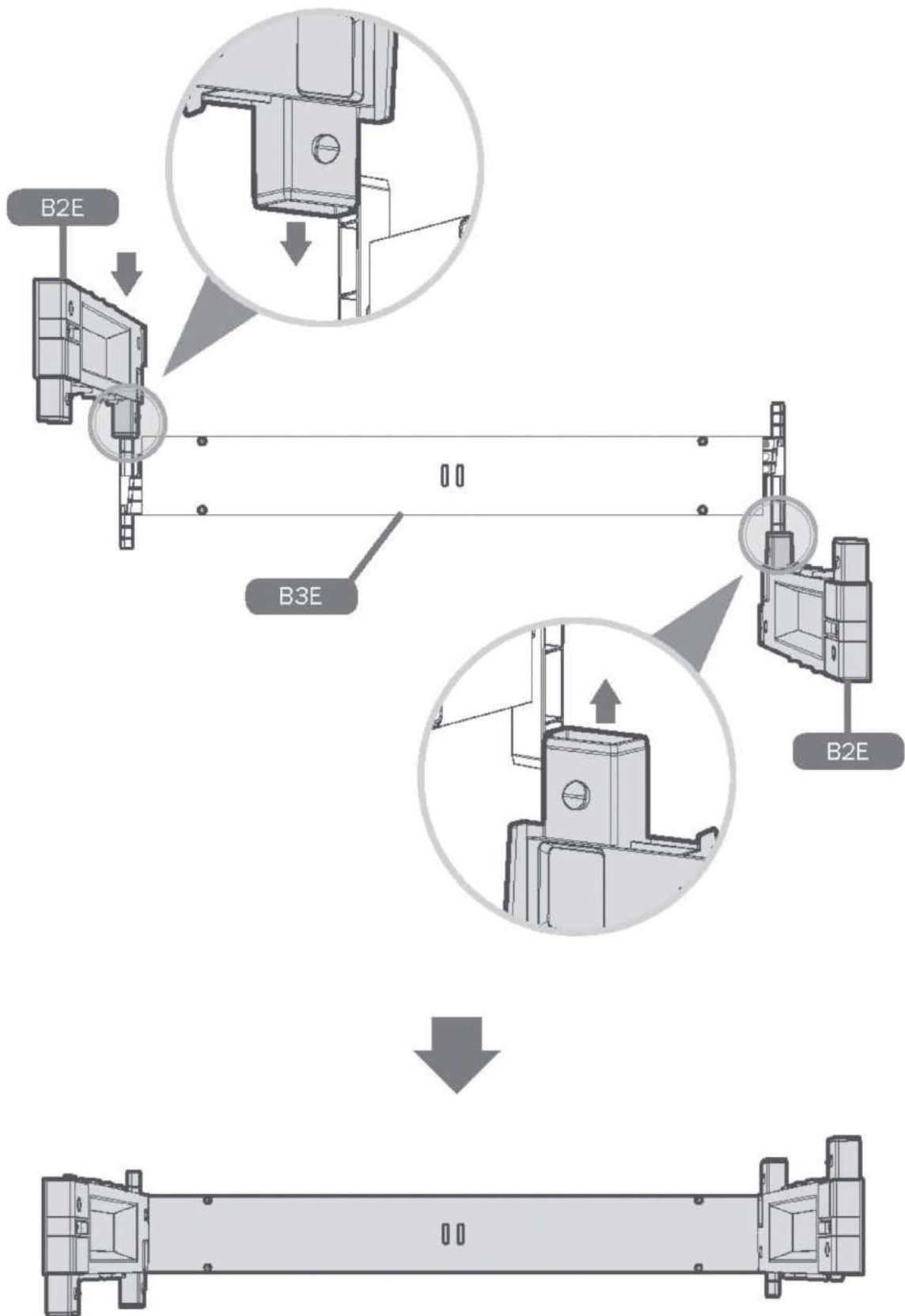

11

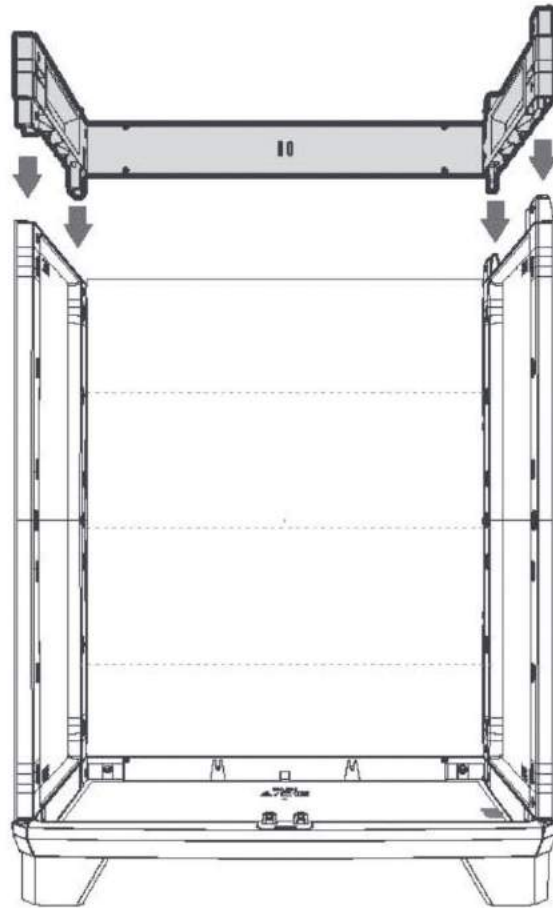

12

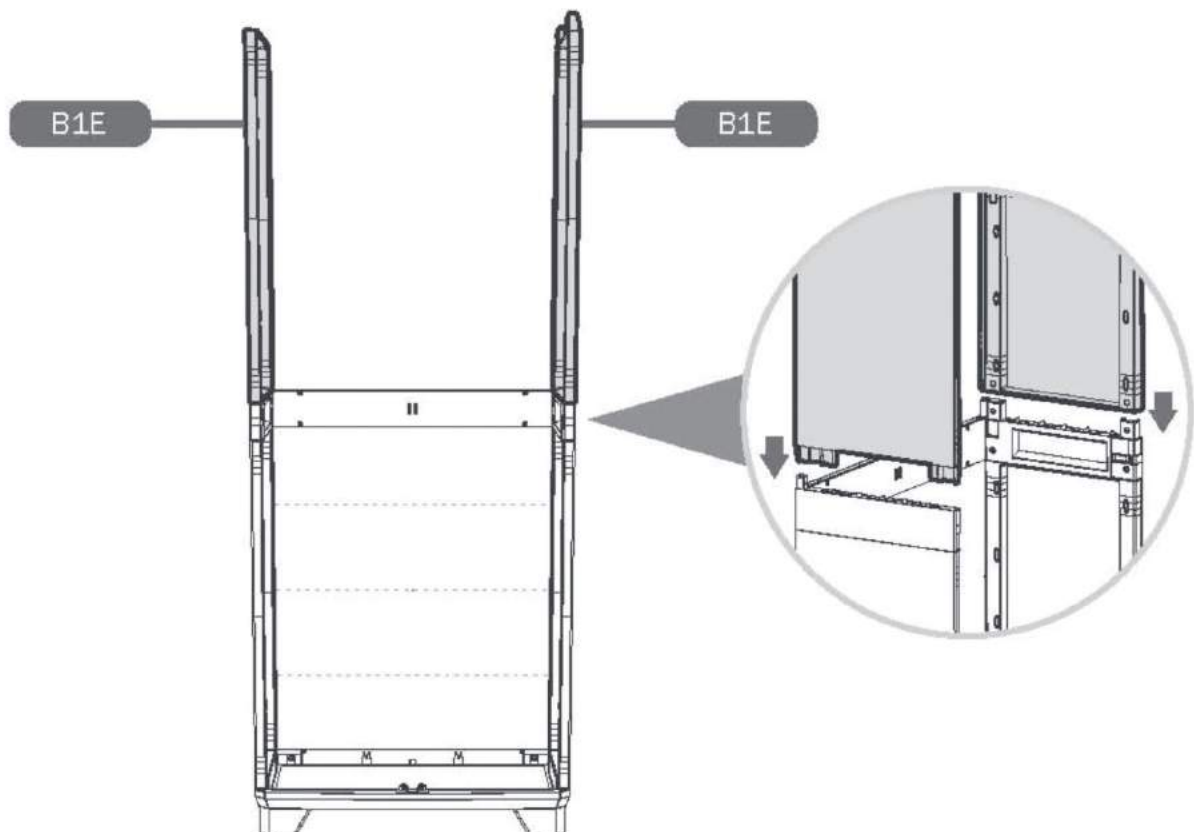

2x [3,9x13 mm]

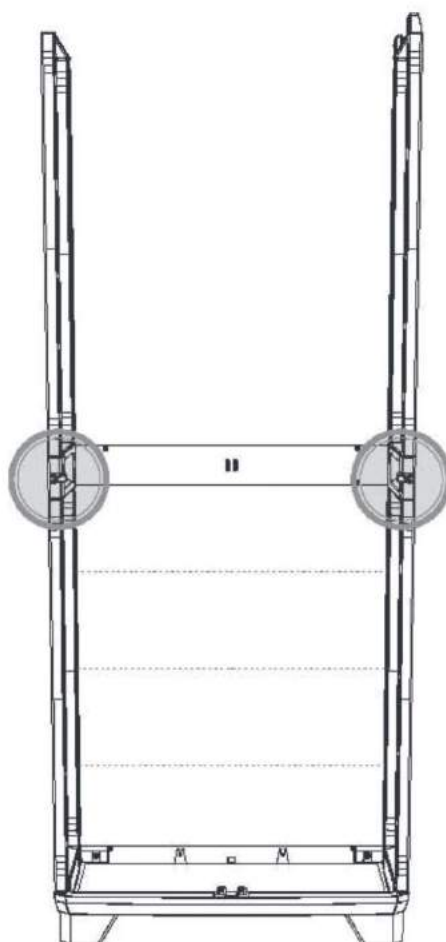
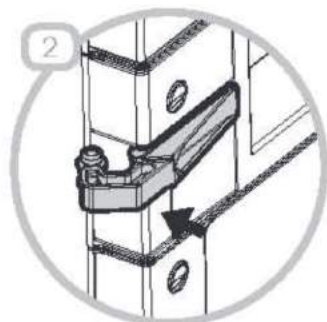

14

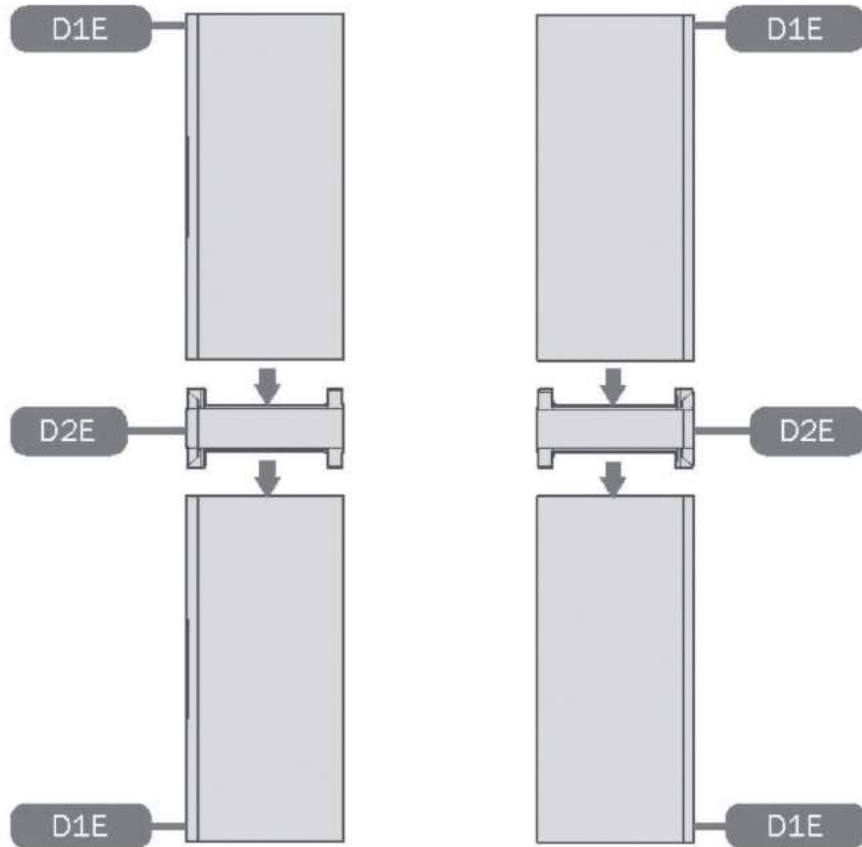

15

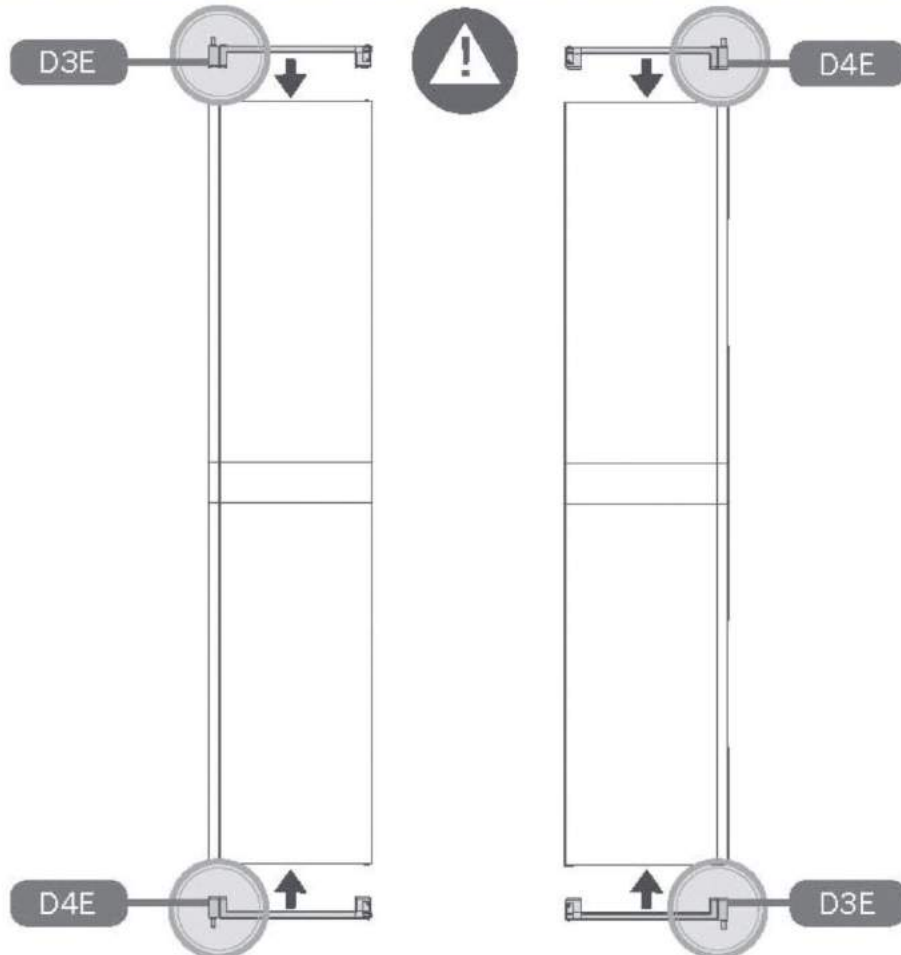

16

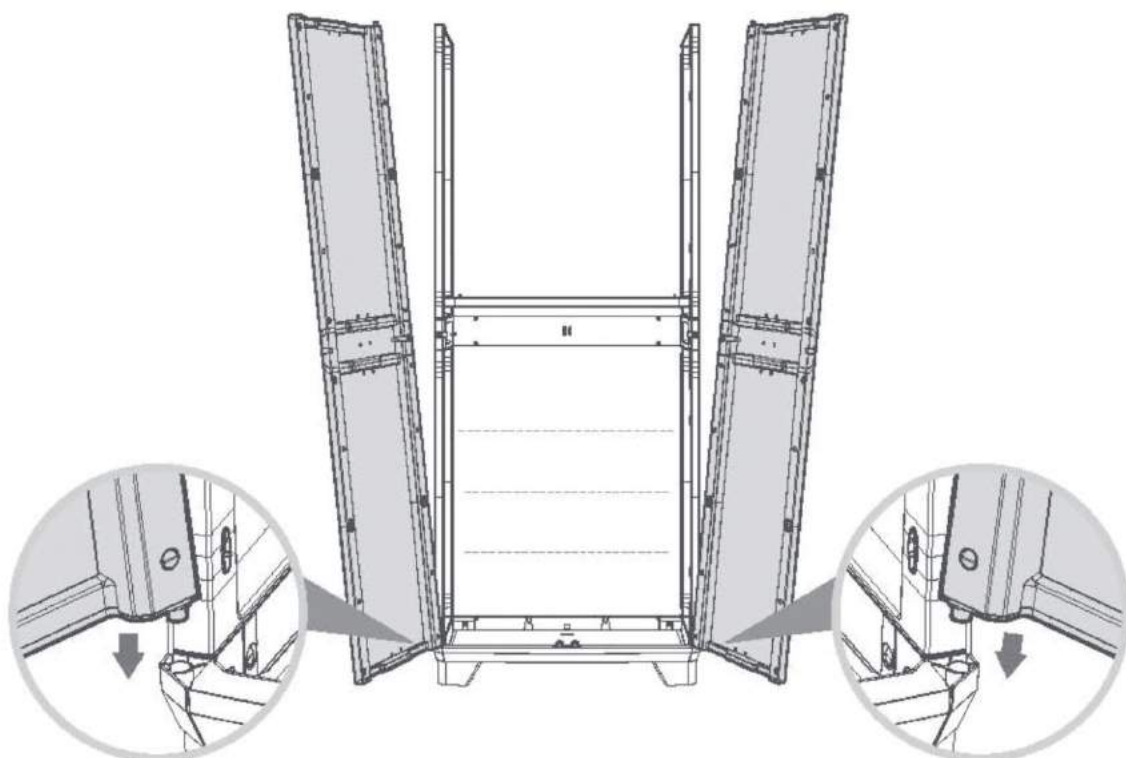

17

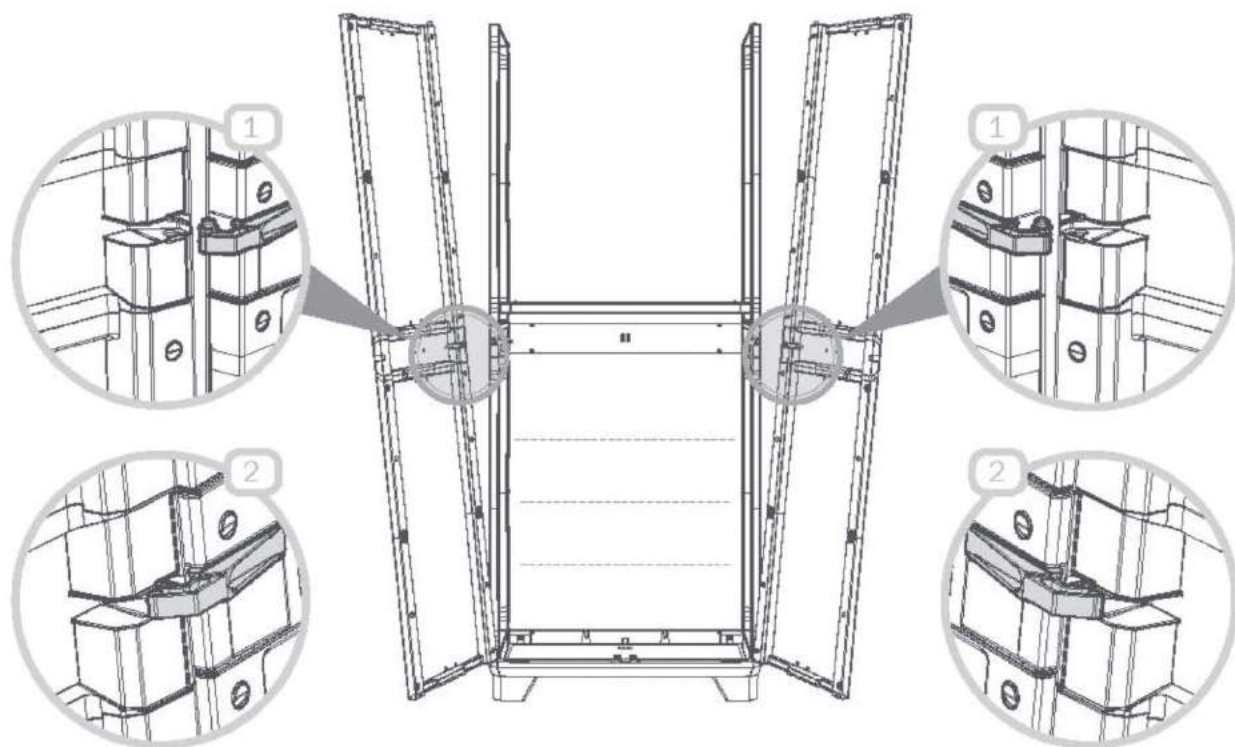

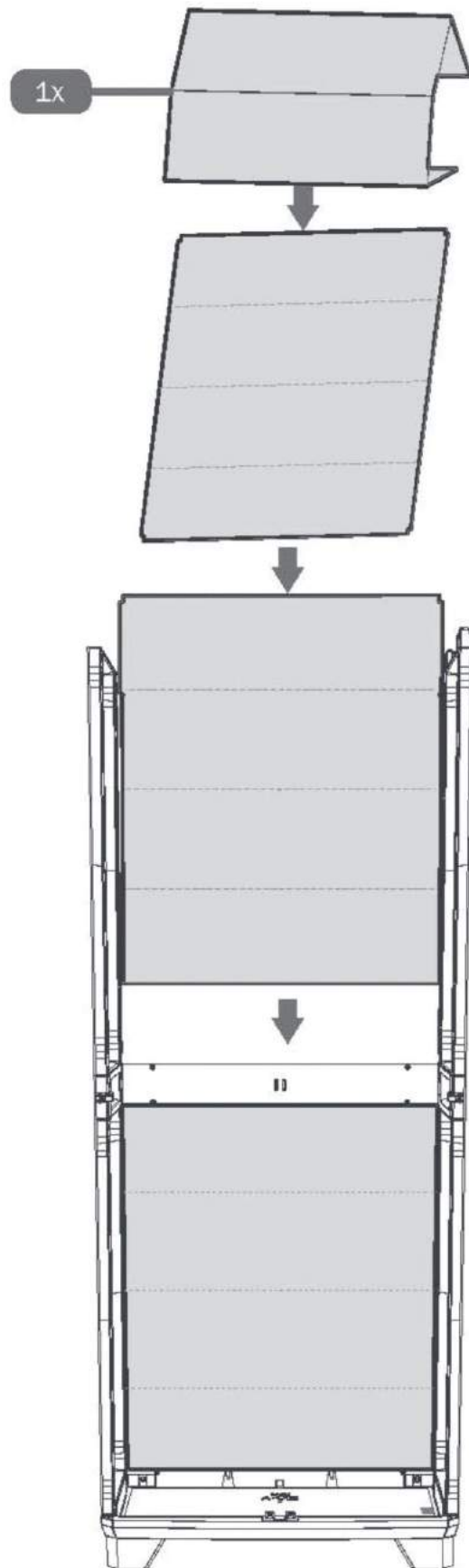

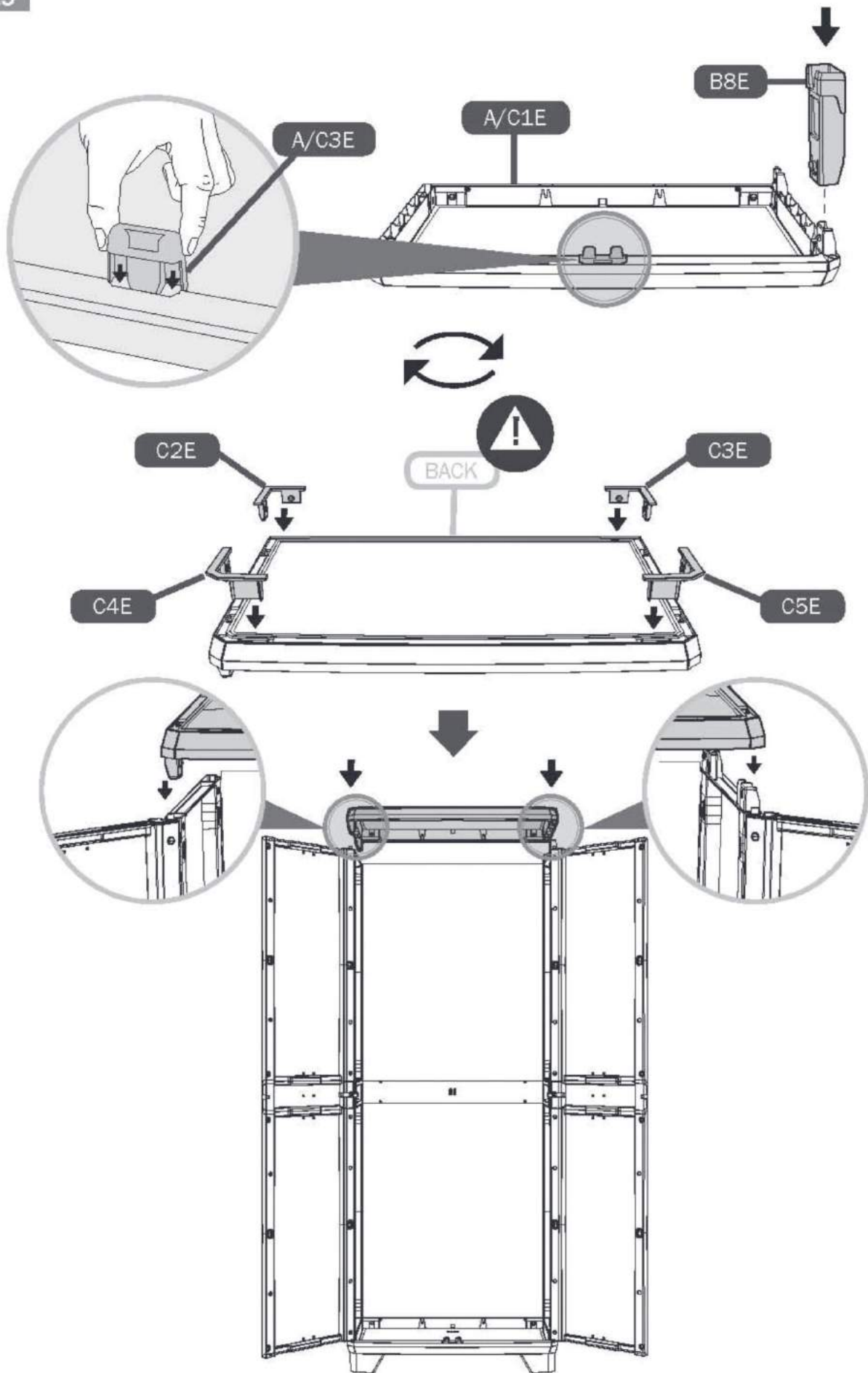

8x [3,9x13 mm]

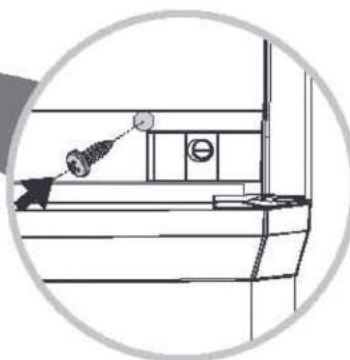
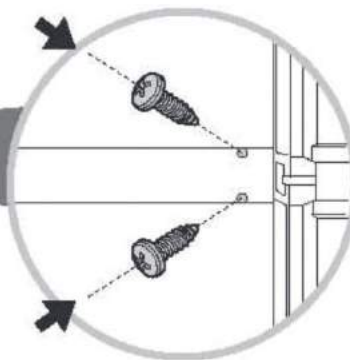
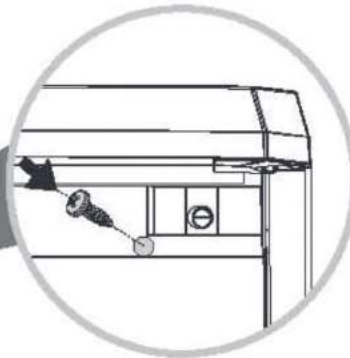
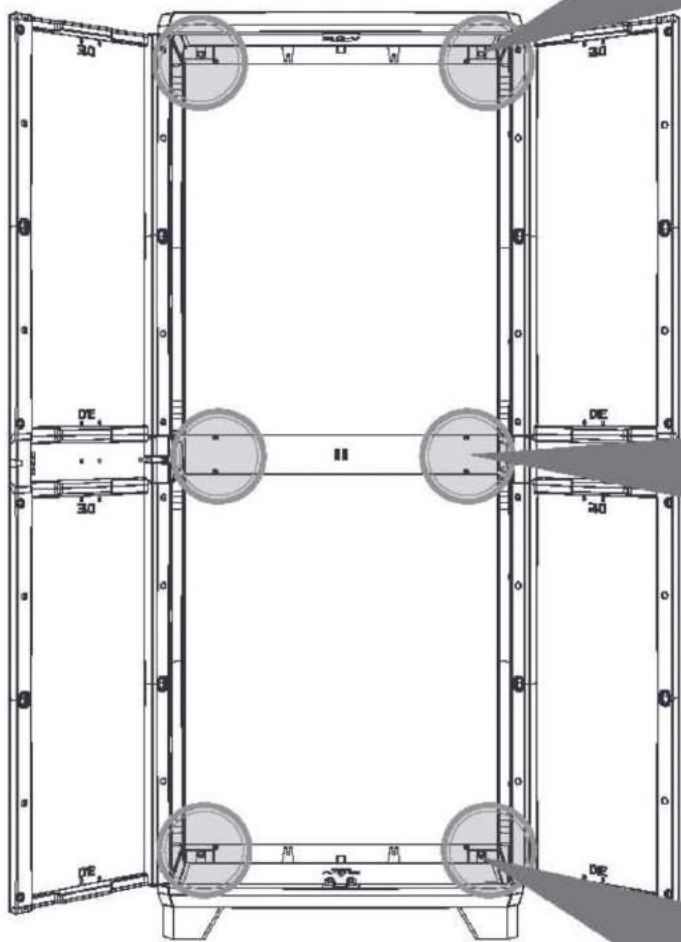
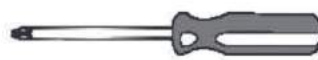

21

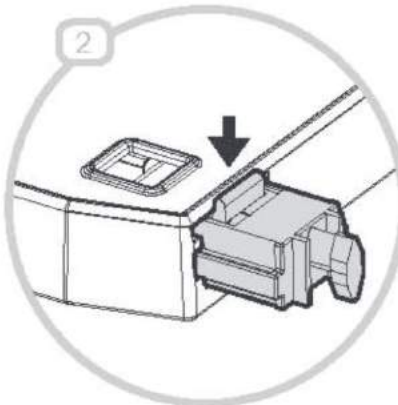
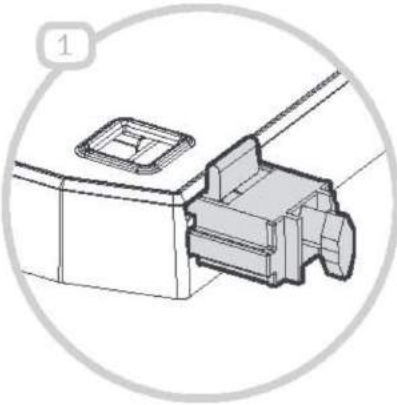
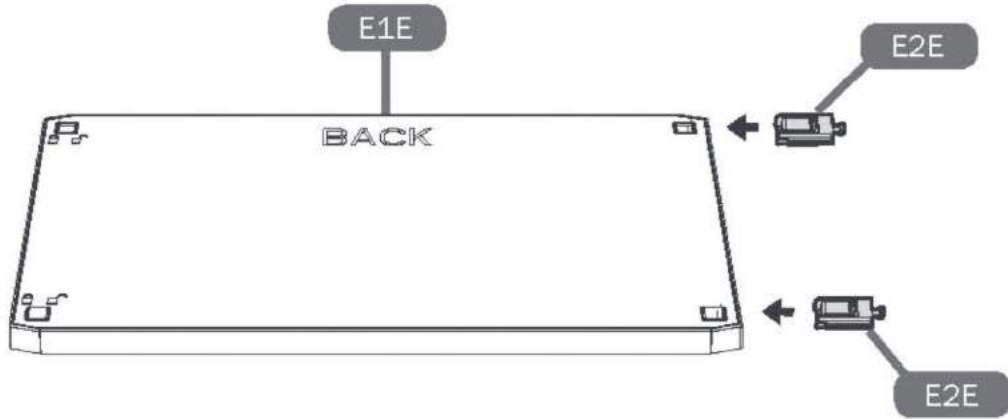

X3

22

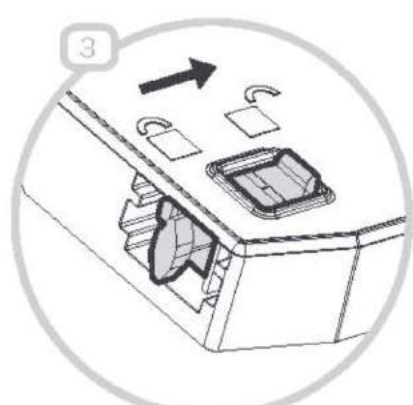
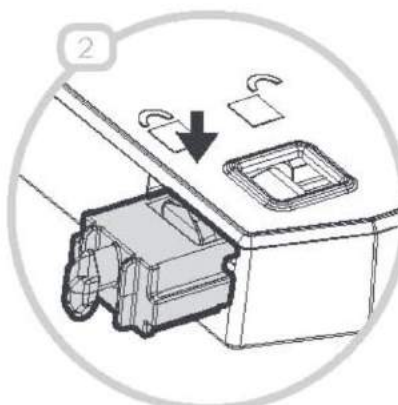
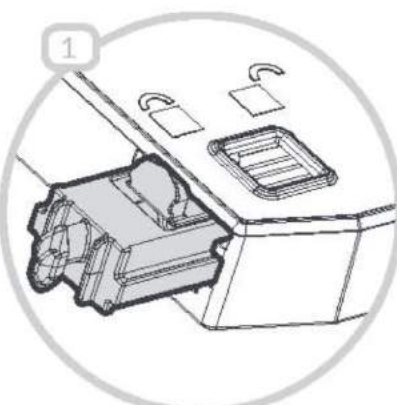
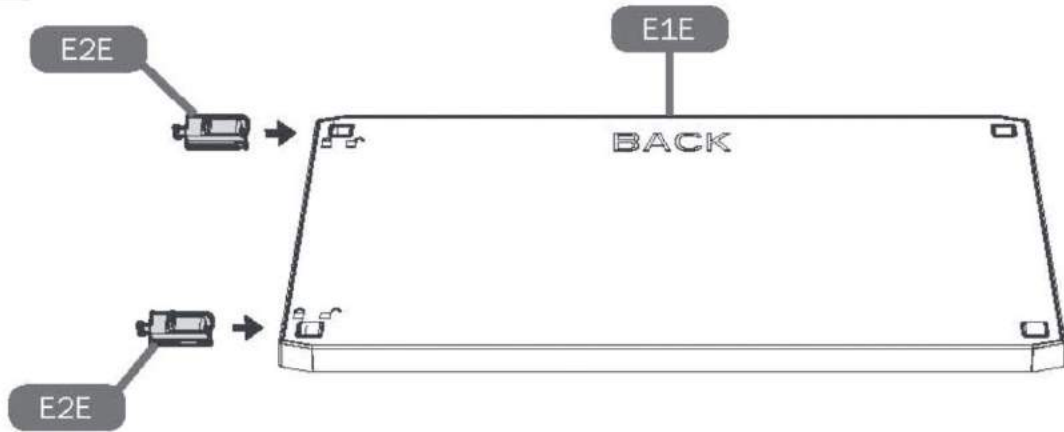

X3

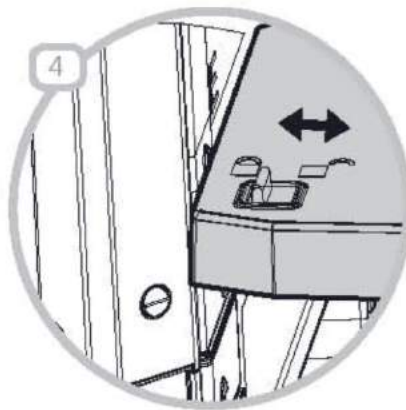
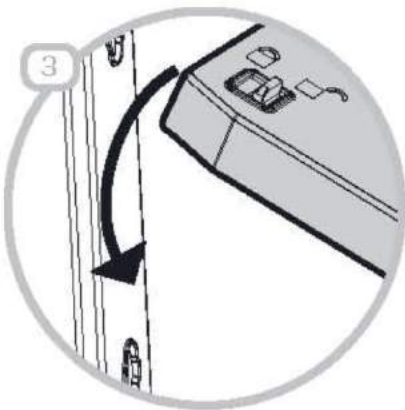
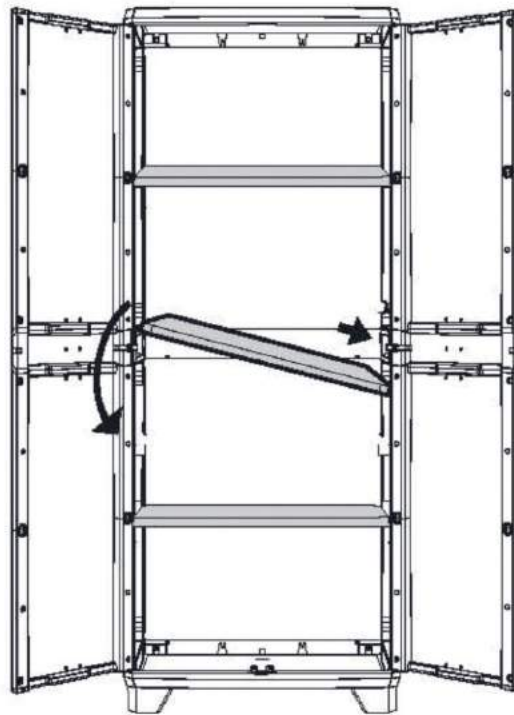
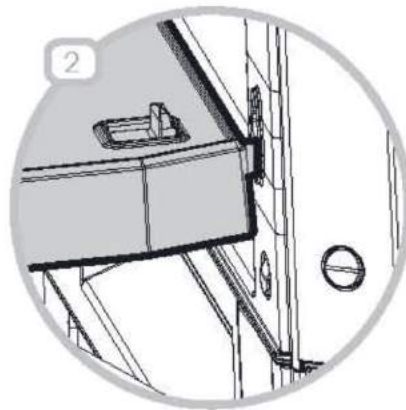
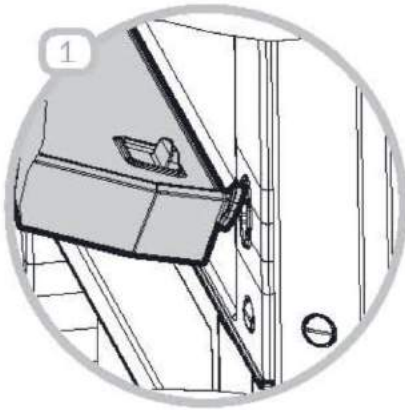

X3

4x [4,2x22 mm]

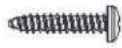

2x

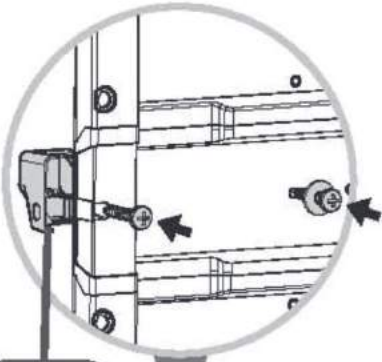

D8E

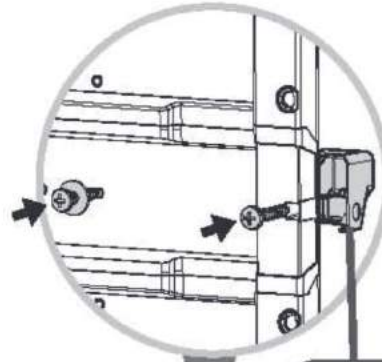

D7E

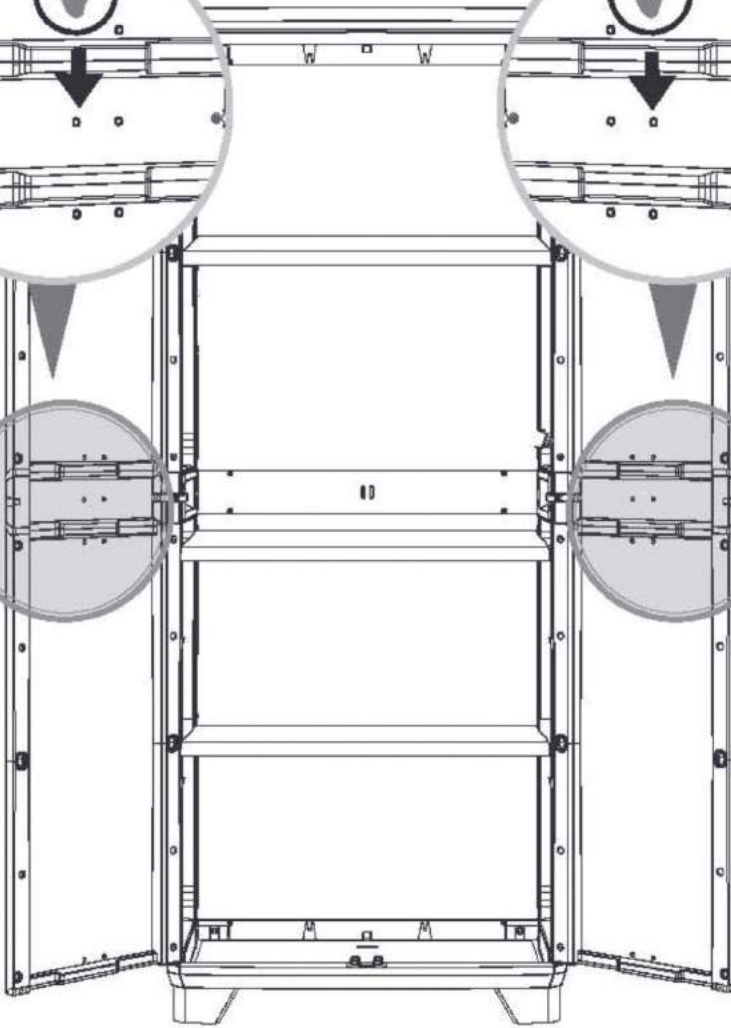
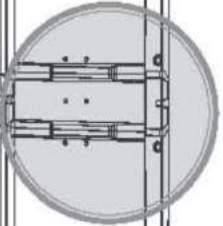
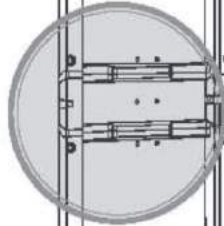
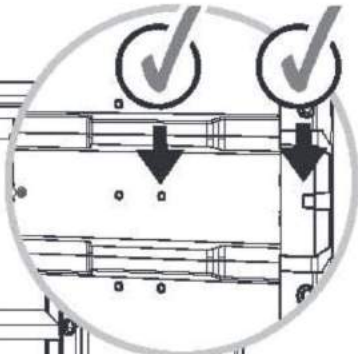
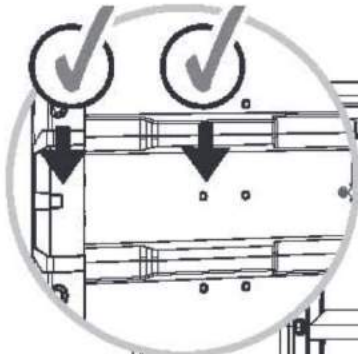

IT Per garantire maggiore stabilità dell'armadio su superfici irregolari, utilizzare le viti di regolazione poste sotto i piedi anteriori. GB For optimum stability on uneven surfaces, regulate the cupboard using the screws under the front feet. DE Um dem Schrank auf unebenen Flächen mehr Stabilität zu verleihen, verwenden Sie bitte die Stellschrauben unter den vorderen Füßen. FR Pour garantir une meilleure stabilité de l'armoire sur des surfaces irrégulières, utiliser les vis de réglage placées sous les pieds avant. ES Utilice los tornillos de regulación (situados bajo los pies delanteros) para asegurar una mayor estabilidad del armario. NL Gebruik de stelschroeven onder de voorpoten om een betere stabiliteit van de kast op onregelmatige vloeren te verzekeren. TR Dolabin düzgün olmayan yüzeyler üzerinde daha sağlam bir şekilde durmasını sağlamak için ön ayakların altındaki ayar vidalarını kullanın. GR Για να εξασφαλίσετε τη μεγαλύτερη σταθερότητα της ντουλάπας πάνω σε ανώμαλες επιφάνειες χρησιμοποιήστε τις βίδες ρύθμισης που βρίσκονται κάτω από τα μπροστινά πόδια. RU Для того, чтобы обеспечить наибольшую устойчивость шкафа на неровной поверхности, воспользуйтесь регулировочными винтами, расположенными под передними ножками. RO Pentru a garanta o stabilitate mai mare a dulapului pe suprafețe neregulate, utilizați șuruburile de reglare aflate sub picioarele din față. CZ Abyste zajistili co největší stabilitu skříně na nerovném povrchu, použijte regulační šrouby umístěné pod předními nožkami. PL Aby zagwarantować większą stabilność szafy, w przypadku nieregularnego podłoża, należy użyć śrub regulacyjnych, znajdujących się pod przednimi nóżkami. PT Para garantir maior estabilidade do armário sobre superfícies irregulares, utilize os parafusos de regulação situados em baixo dos pés dianteiros.

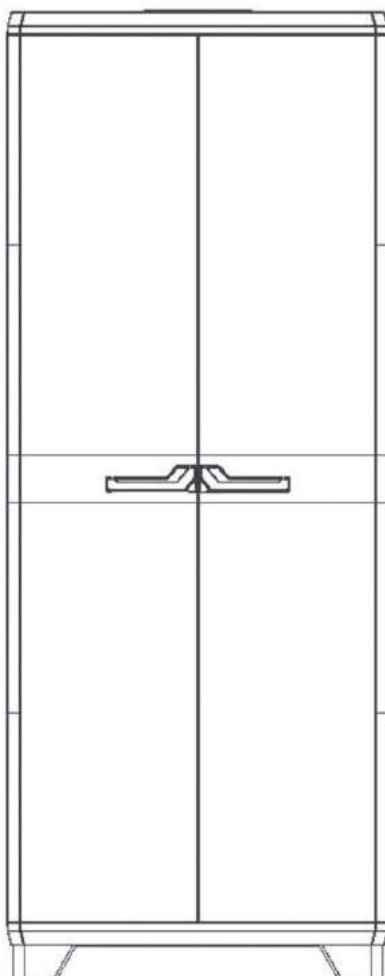

IT Fissare l'armadio a muro (viti e tasselli non inclusi). Scegliere il tassello in base alla superficie di appoggio. **GB** Fasten the cupboard to the wall (screws and anchors not included). Choose the anchor according to the surface. **DE** Befestigen Sie den Schrank an der Wand (Schrauben und Dübel sind nicht im Lieferumfang enthalten). Den Dübel je nach Stellfläche wählen. **FR** Fixer l'armoire au mur (vis et chevilles non incluses). Choisir la cheville en fonction de la surface d'appui. **ES** Fije el armario en la pared (la dotación no incluye tornillos y tacos). Elija el taco en función de la superficie de apoyo. **NL** Bevestig de kast aan de muur (schroeven en pluggen niet bijgeleverd). Kies de plug aan de hand van het steunoppervlak. **TR** Dolabı duvara sabitleyin (vidalar ve dübeller dahil değil). Destek yüzeyine göre dübel seçin. **GR** Στερεώστε την ντουλάπα στον τοίχο (βίδες και ούπα δεν περιλαμβάνονται). Επιλέξτε το ούπα ανάλογα με την επιφάνεια στήριξης. **RUS** Закрепите шкаф на стене (шурупы и дюбели не включены в поставку). Возьмите дюбель, пригодный для материала поверхности, у которой ставится шкаф. **RO** Fixați dulapul la perete (șuruburi și dibluri neincluse în dotare). Alegeți diblul în funcție de suprafața pe care urmează să se fixeze. **CZ** Připevněte skříň ke zdi (šrouby a hmoždinky nejsou součástí dodávky). Zvolte hmoždinku podle povrchu podkladu. **PL** Przymocować szafę do muru (śruby i kołki nie są zawarte w dostawie). Dobrać kołek w zależności od powierzchni oparcia. **PT** Fixe o armário na parede (parafusos e buchas não incluídos). Escolher a bucha conforme a superfície de apoio.

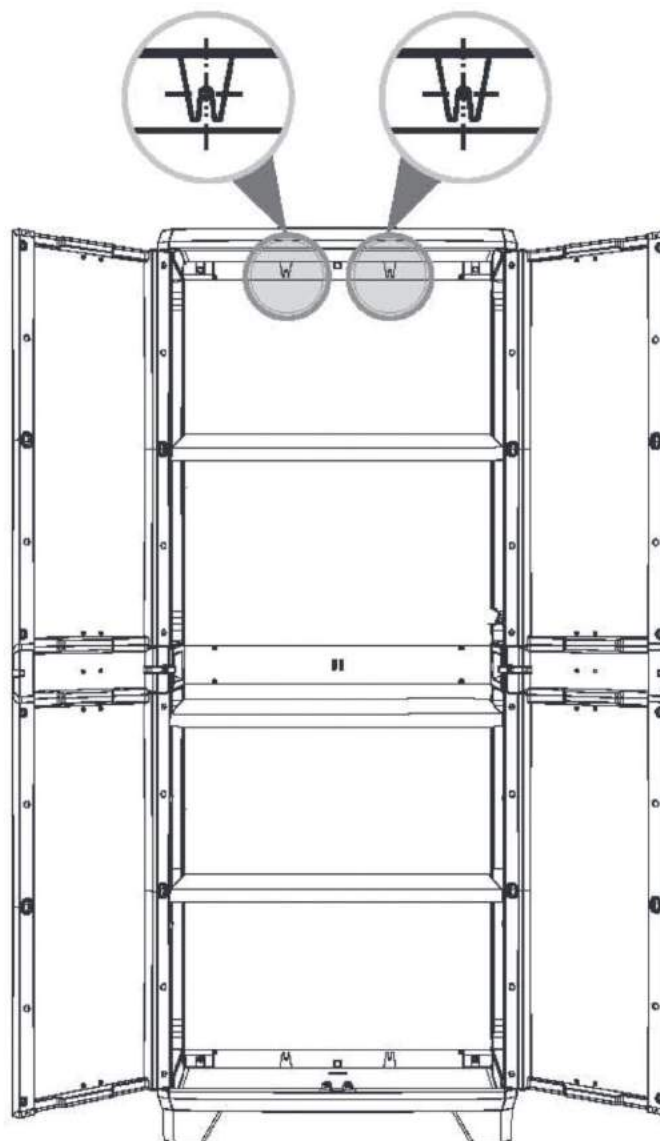







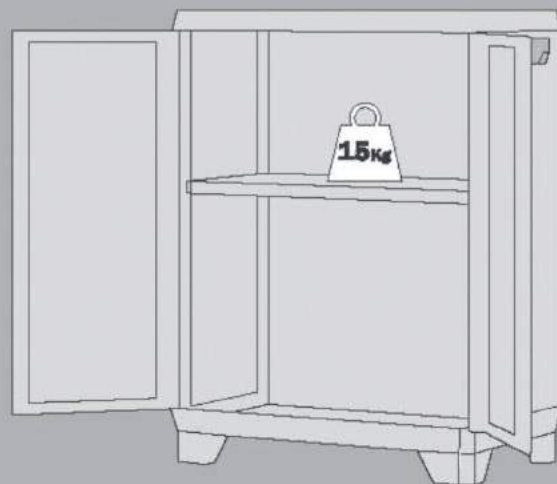
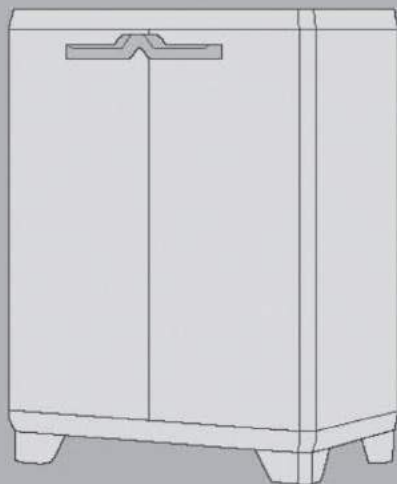

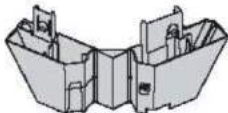
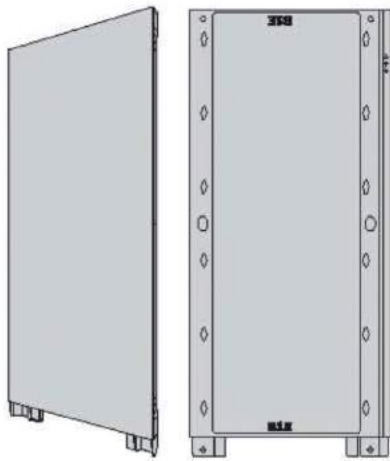

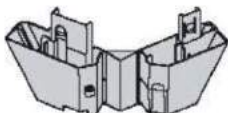
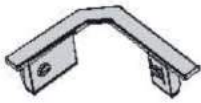
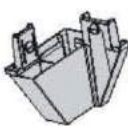

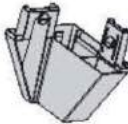
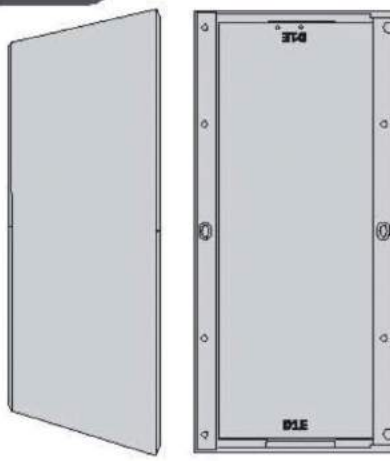

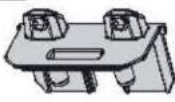

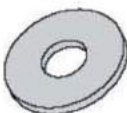
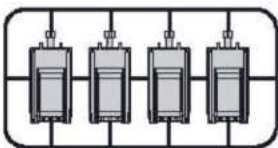
STILO

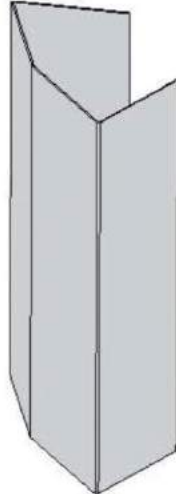
cm 68x39x90 h

IT Istruzioni per il montaggio DE Assembly instruction DE Montageanleitungen FR Instructions pour le montage ES Instrucción para el montaje NL Instructies voor de montage TR Montaj talimatları GR Οδηγίες συναρμολόγησης RU Инструкции за монтаж RO Instrucțiuni de montaj CZ Návod na montáž PL Instrukcja montażu PT Instruções de montagem

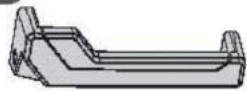

<p>1x E1E</p> 	<p>A2E</p> 	<p>2x B1E</p> 
<p>2x A/C1E</p> 	<p>A3E</p> 	
<p>C4E</p> 	<p>A4E</p> 	
<p>C5E</p> 	<p>A5E</p> 	<p>2x D1E</p> 
<p>C3E</p> 	<p>2x A/C3E</p> 	
<p>C2E</p> 	<p>2x</p> 	
<p>E2E</p> 	<p>2x</p> 	<p>1x</p> 
<p>4x [4,2x22 mm]</p> 	<p>4x [3,9x13 mm]</p> 	
<p>2x D4E</p> 	<p>2x D3E</p> 	
<p>D7E</p> 	<p>D8E</p> 	



IT Conservare il manuale d'uso per referenze future in prossimità del prodotto. Prima di iniziare l'assemblaggio leggere attentamente le avvertenze. **GB** Keep this instruction manual with the product for future reference. Read the instructions carefully before assembly. **DE** Bewahren Sie das Benutzerhandbuch in der Nähe des Produkts auf, damit Sie später jederzeit nachschlagen können. Lesen Sie vor der Montage die Anweisungen aufmerksam durch. **FR** Conservez le manuel d'utilisation à proximité du produit pour de futures références. Lisez attentivement la notice avant de commencer l'assemblage. **ES** Guarde el manual de uso para futuras consultas cerca del producto. Antes de empezar el montaje, lea detenidamente las advertencias. **NL** Bewaar de handleiding in nabijheid van het product voor toekomstige raadpleging. Lees deze voorschriften aandachtig alvorens met de montage te beginnen. **TR** Kilavuzu ileride başvurmak üzere ürüne yakın bir yerde saklayın. Montaja başlamadan önce etiketleri dikkatle okuyun. **GR** Φυλάξτε αυτό το εγχειρίδιο χρήσης κοντά στο προϊόν για μελλοντικές χρήσεις. Πριν ξεκινήσετε την συναρμολόγηση διαβάστε προσεκτικά τις προειδοποιήσεις ασφαλείας. **RU** Храните руководство пользователя поблизости от изделия для дальнейшего к нему обращения. Перед тем, как приступить к сборке, внимательно ознакомьтесь с предупреждениями. **RO** Păstrați manualul de utilizare în apropierea produsului pentru consultări ulterioare. Înainte de a începe asamblarea citiți cu atenție avertismentele. **CZ** Uchovejte tento návod pro jeho případné další použití. Před montáží si pečlivě pročtěte instrukce. **PL** Przechowywać instrukcję obsługi w pobliżu produktu do przyszłych konsultacji. Przed rozpoczęciem montażu przeczytać uważnie pouczenia. **PT** Guarde o manual de uso para consultas futuras na proximidade do produto. Antes de iniciar a montagem, leia os avisos com atenção.

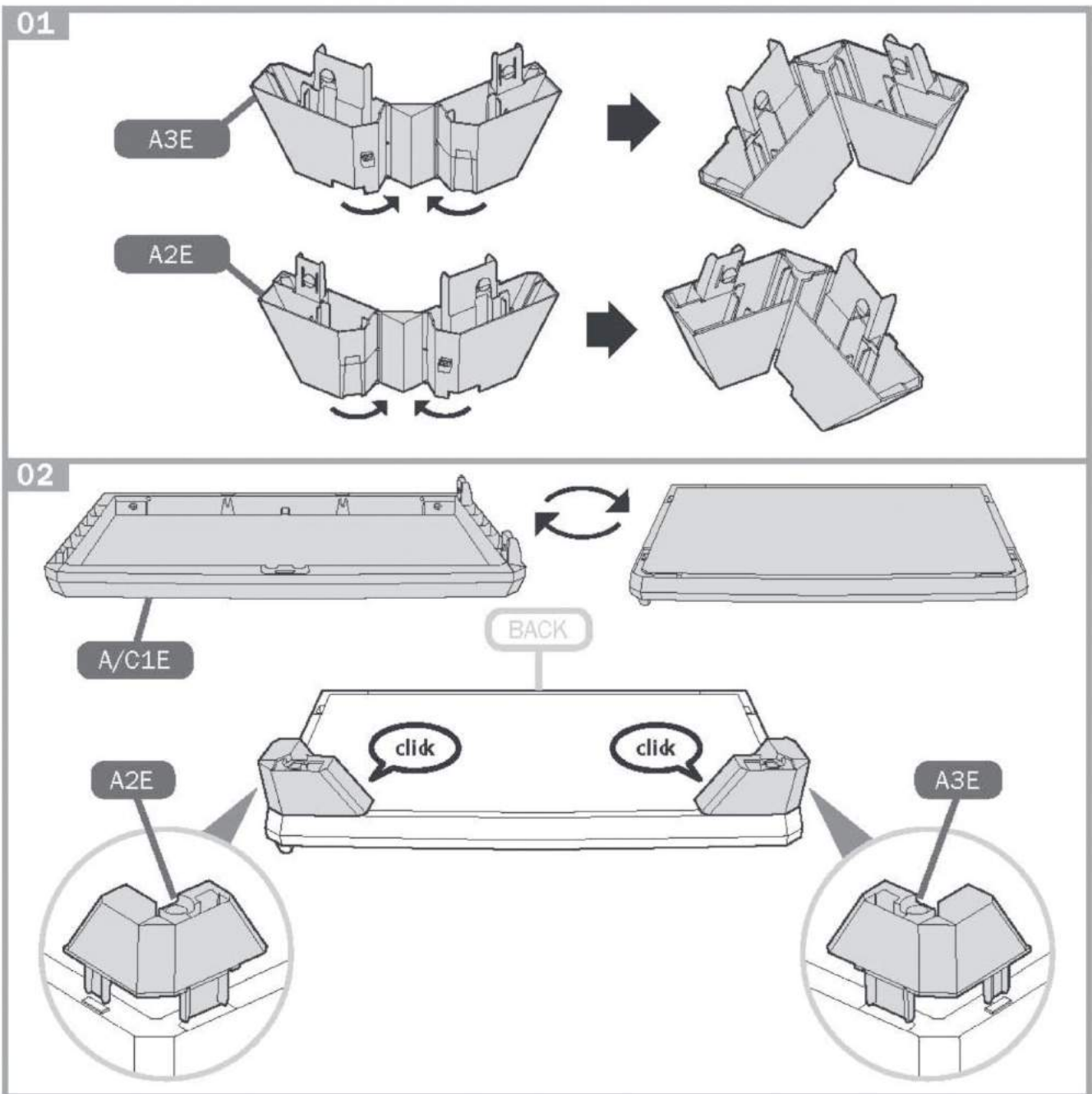

03

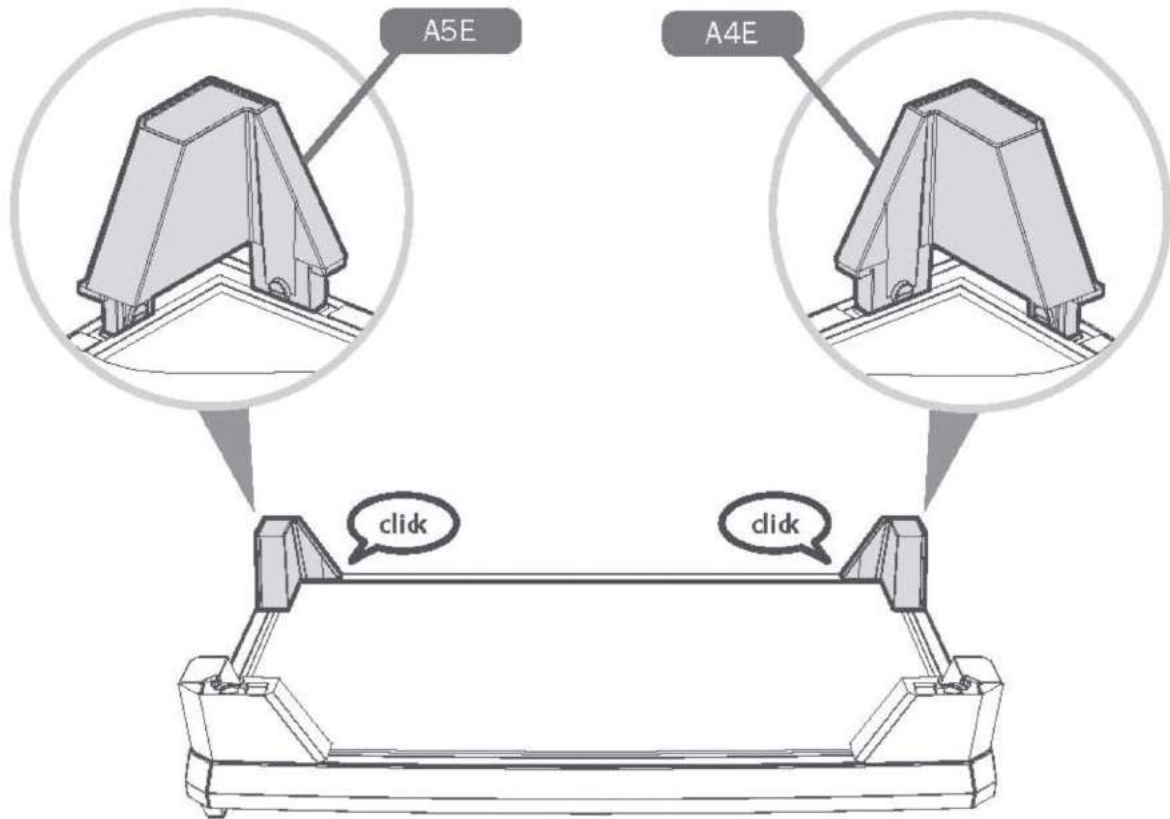

04

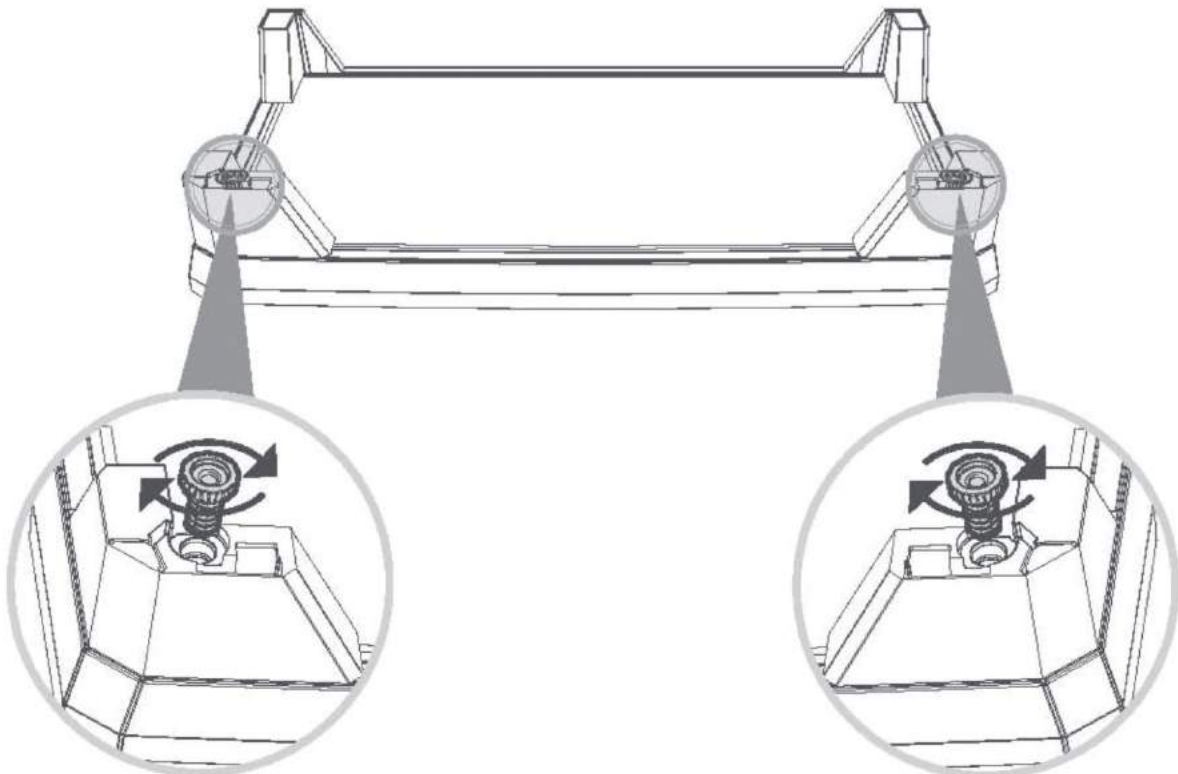

05

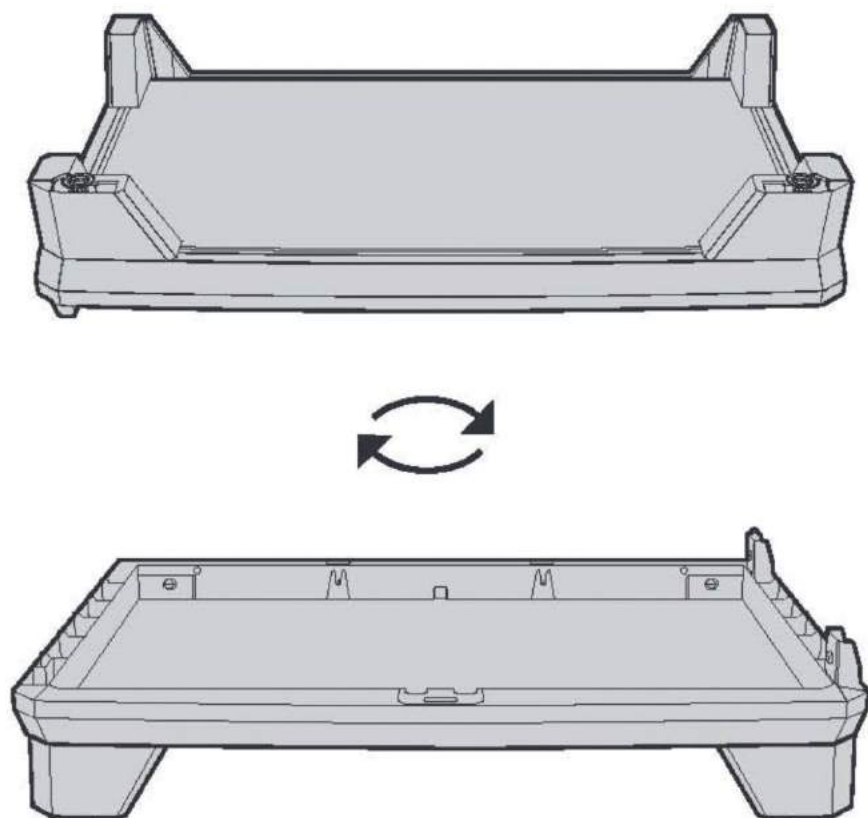

06

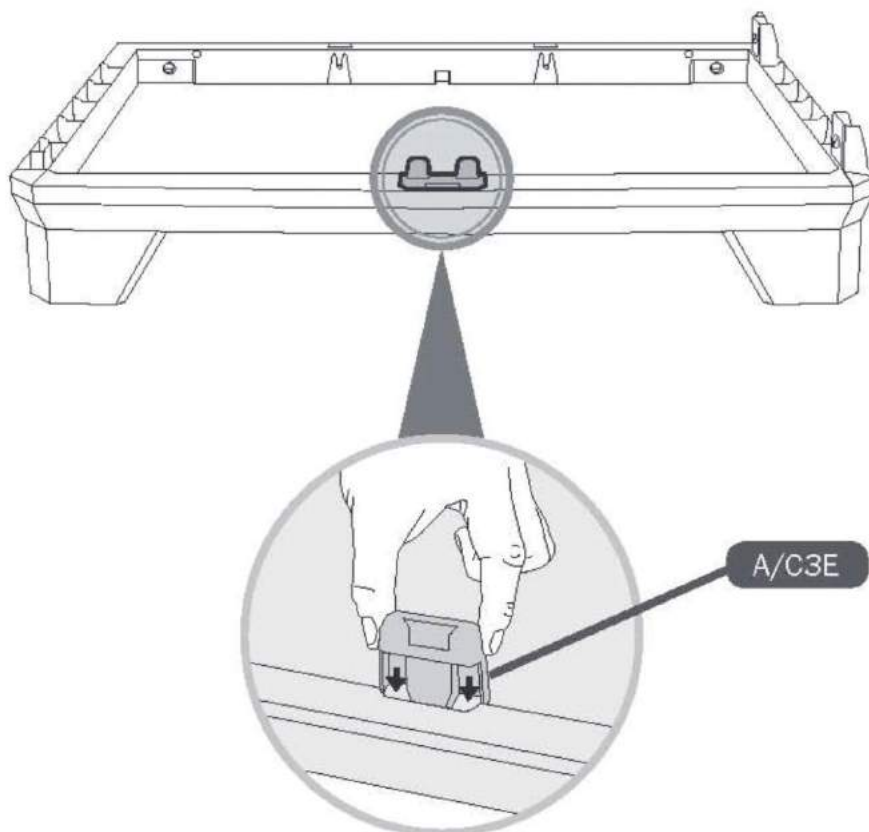

07

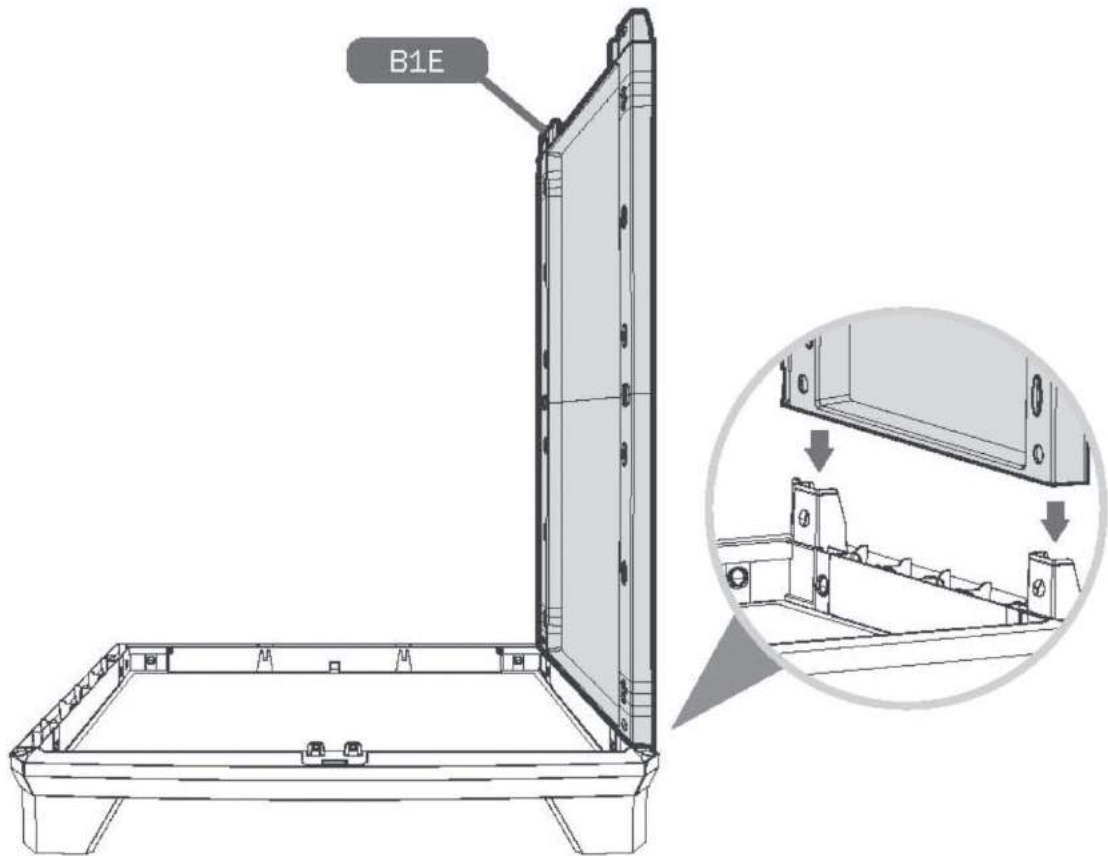

08

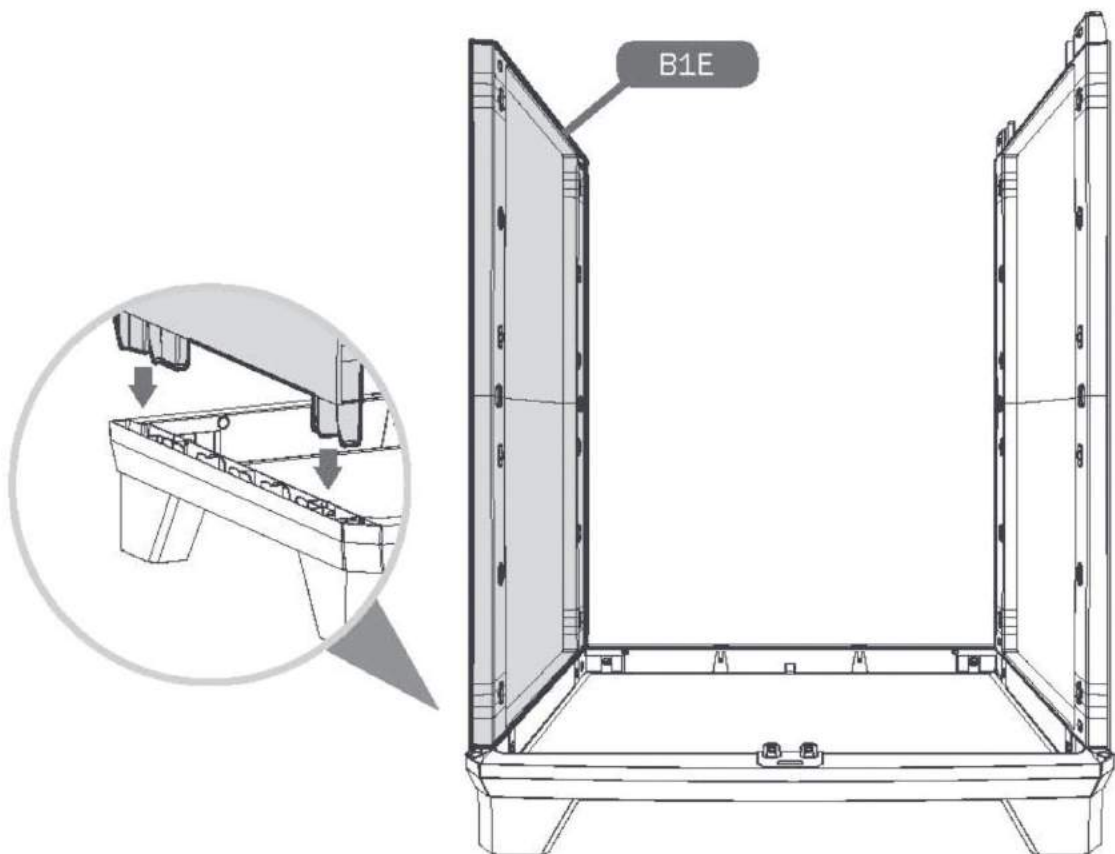

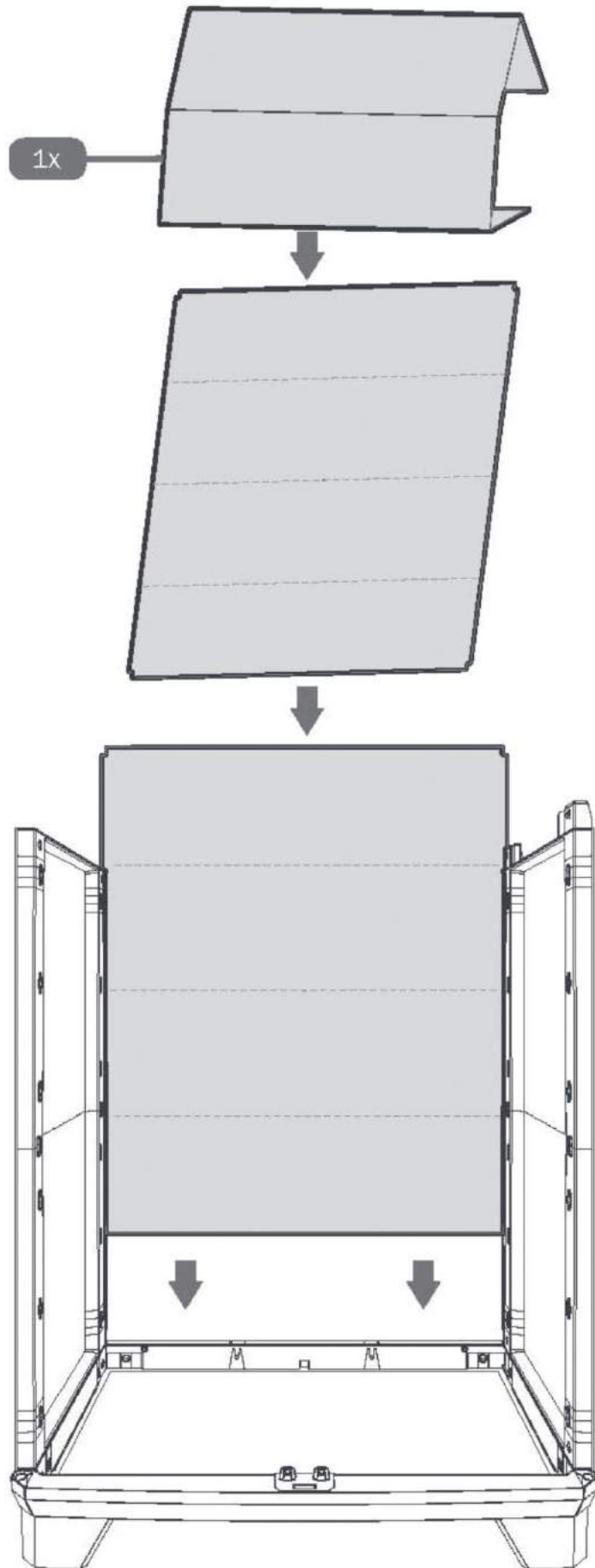

10

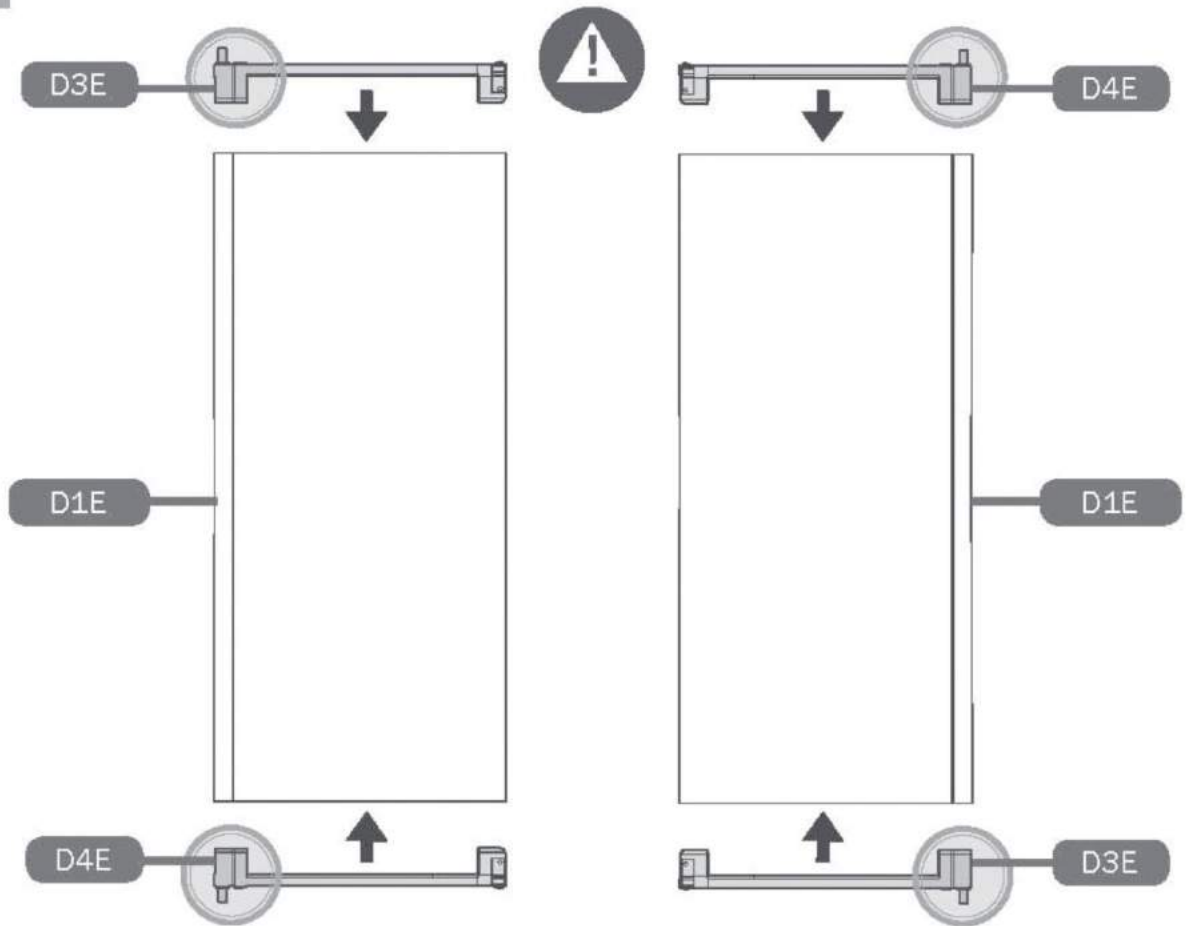

11

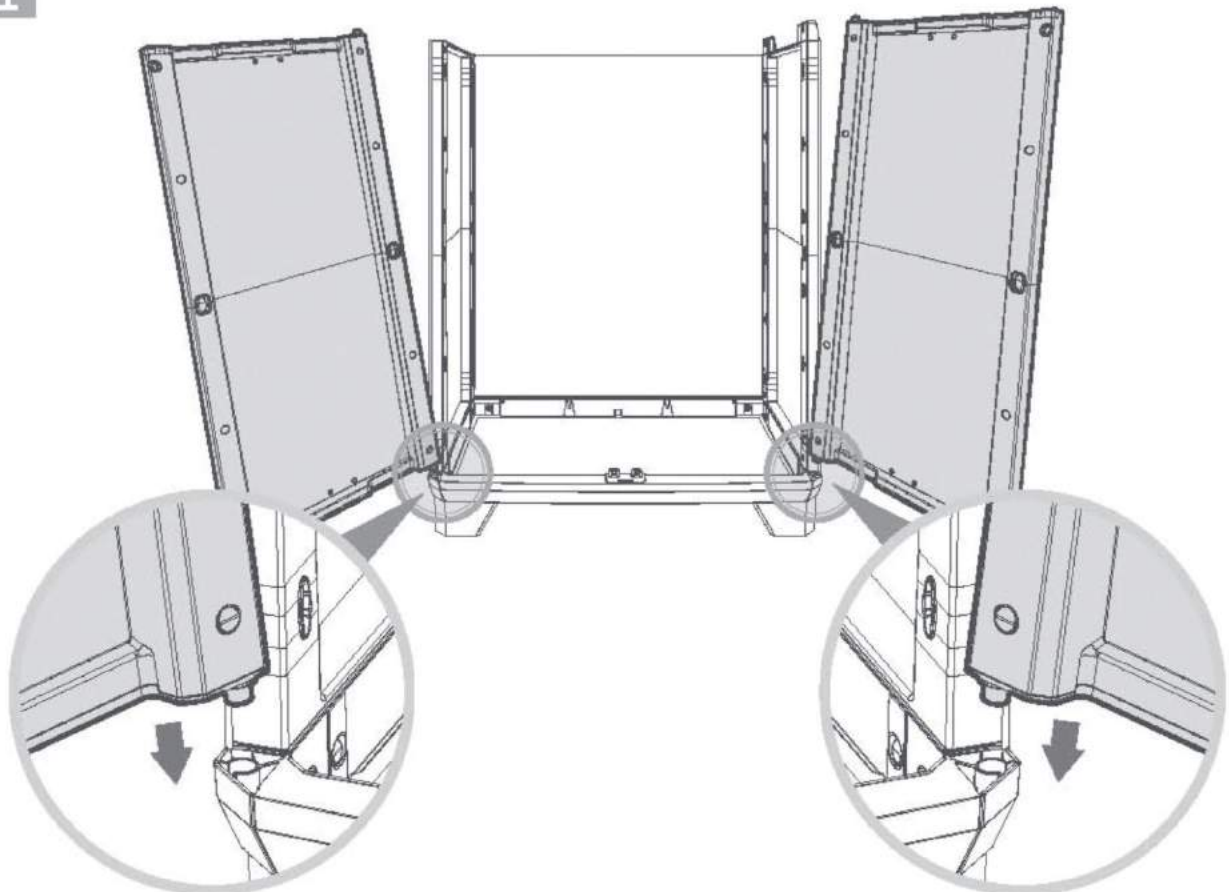

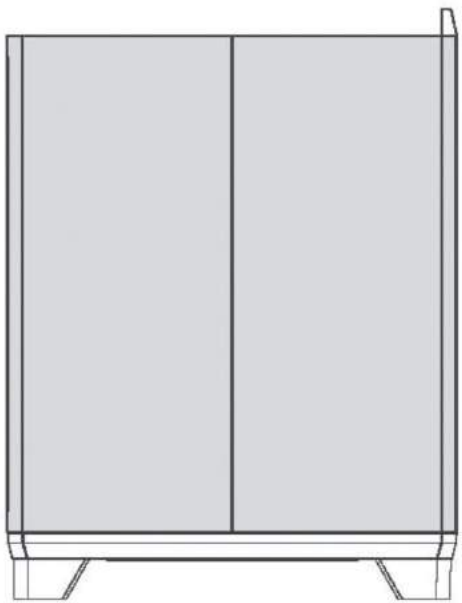
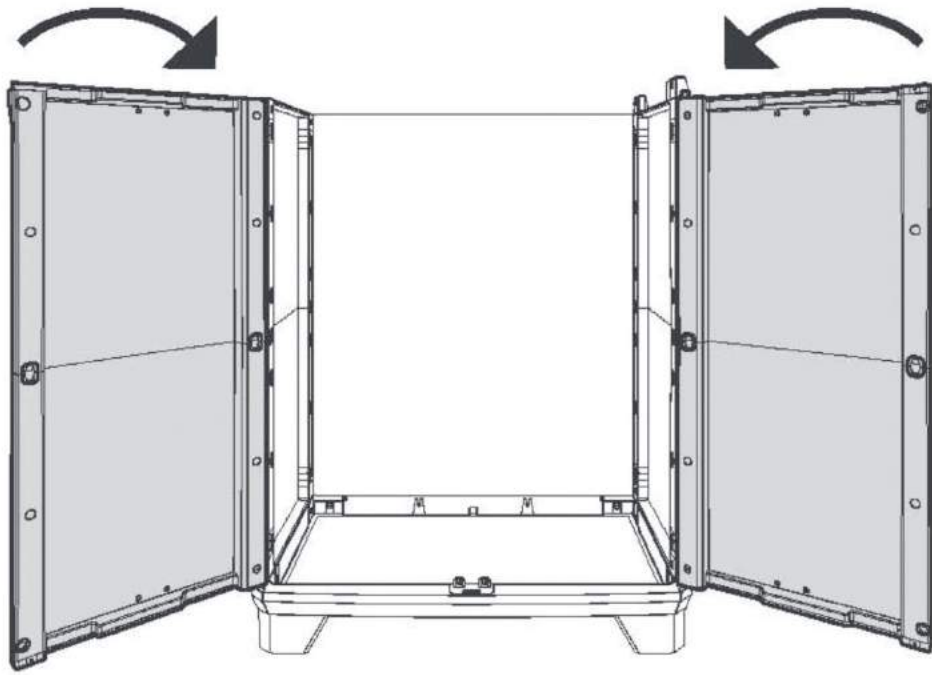

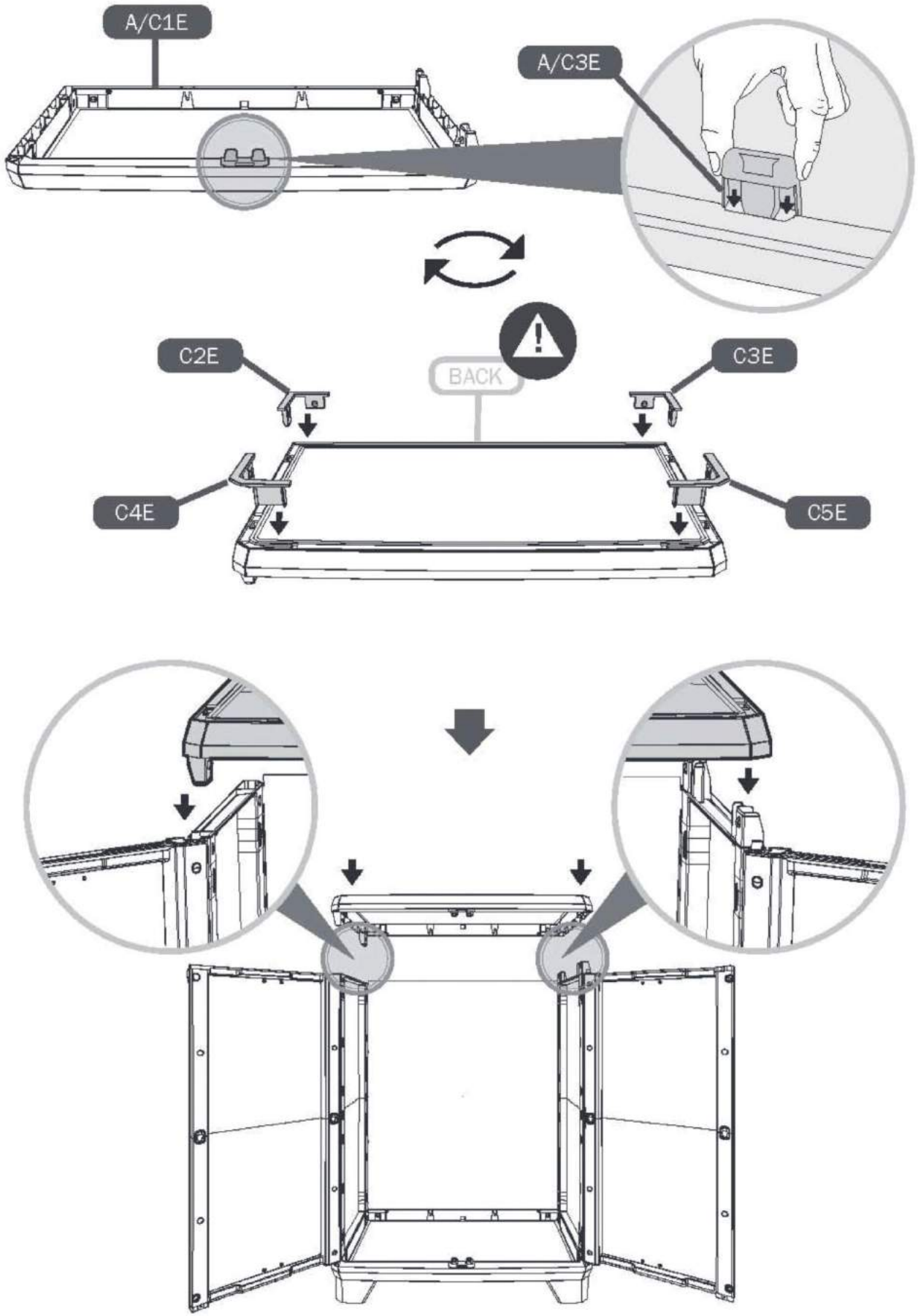

4x [3,9x13 mm]

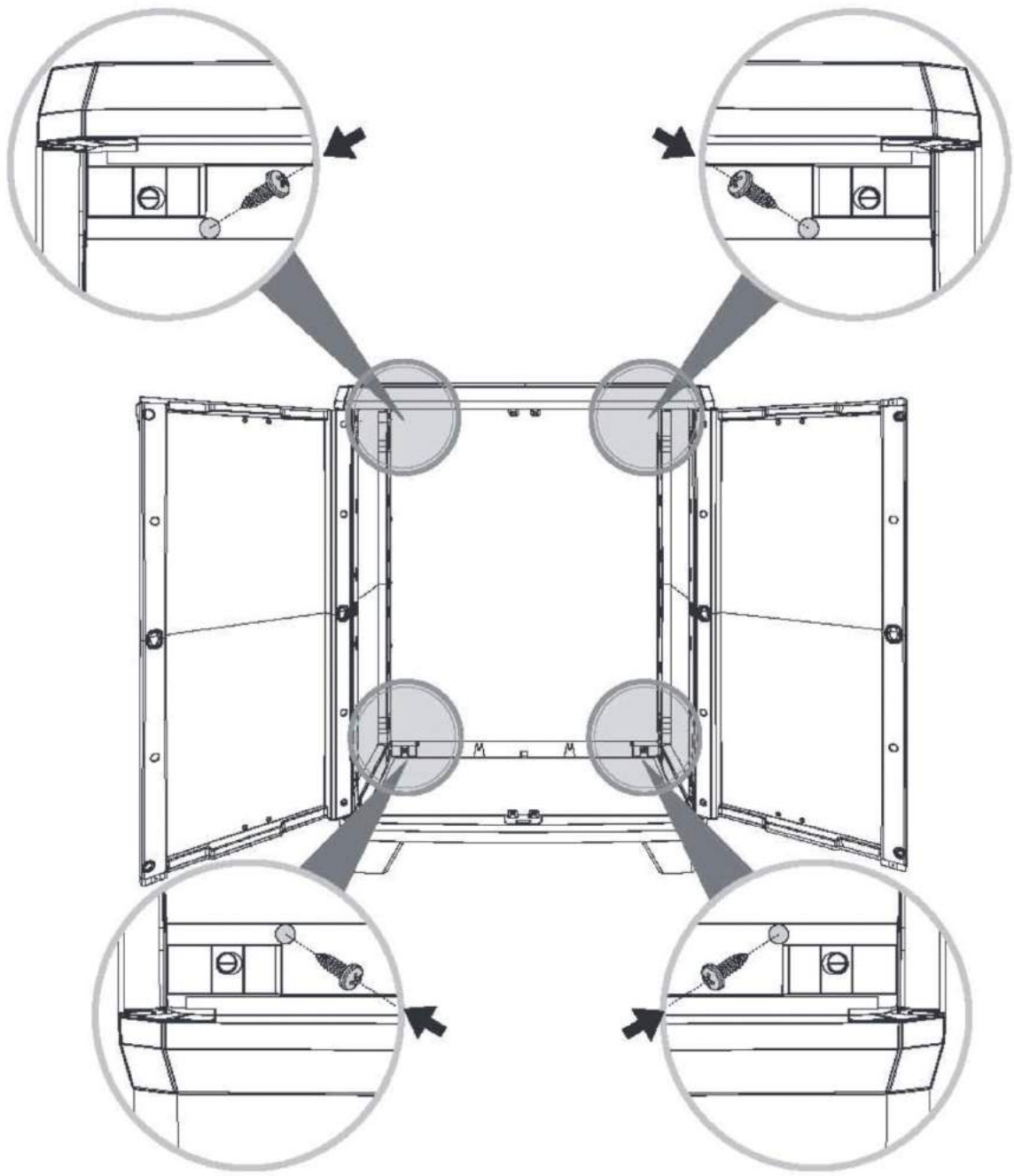
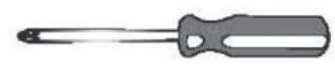

15

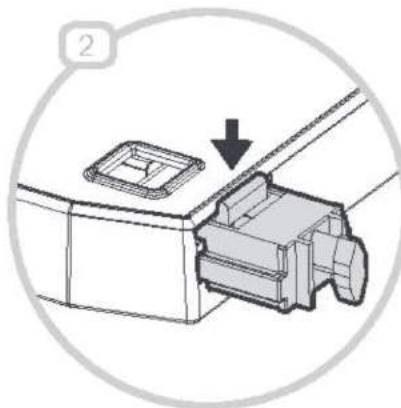
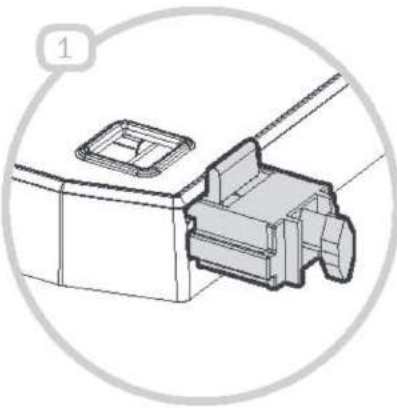
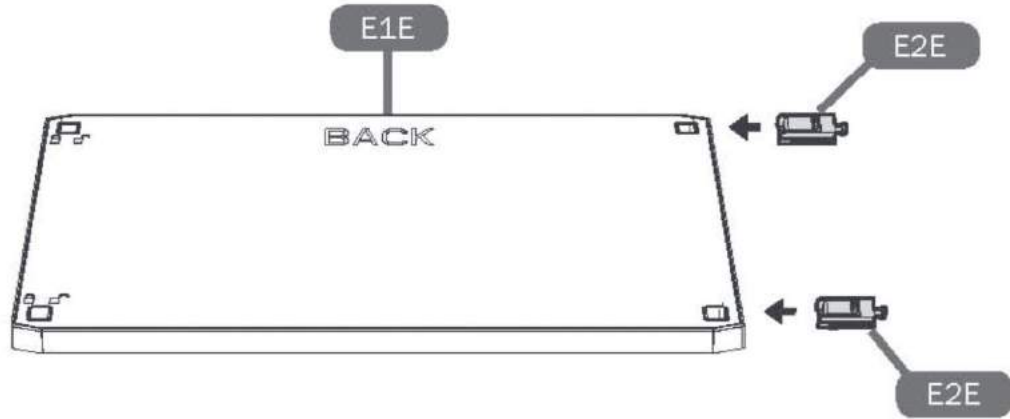

16

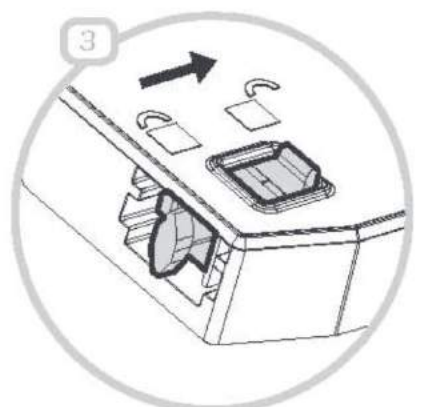
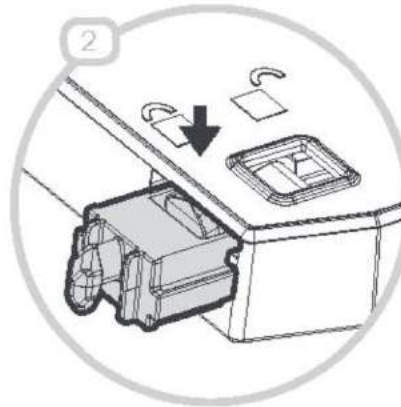
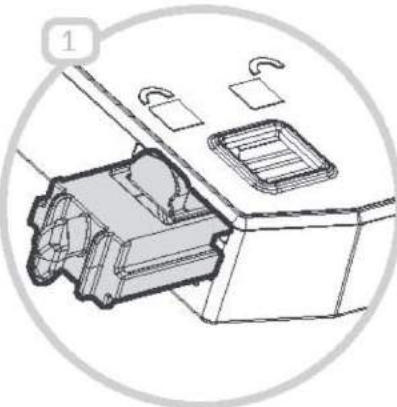
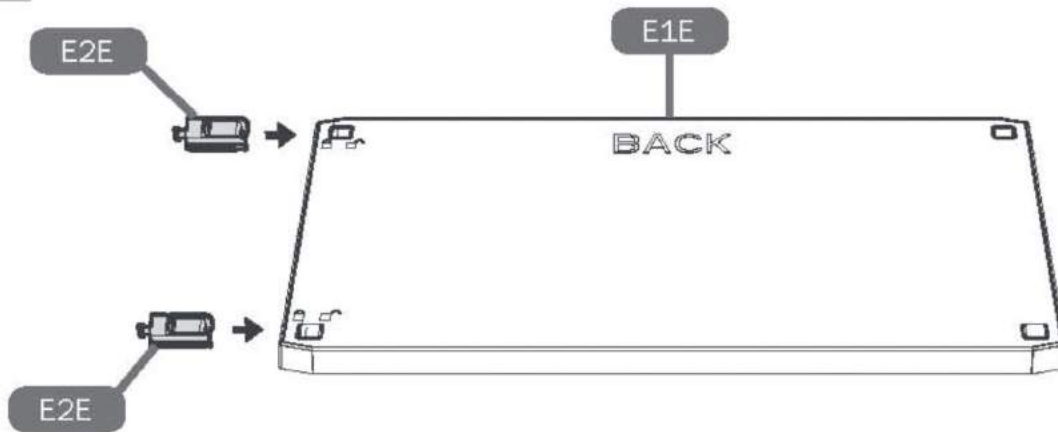

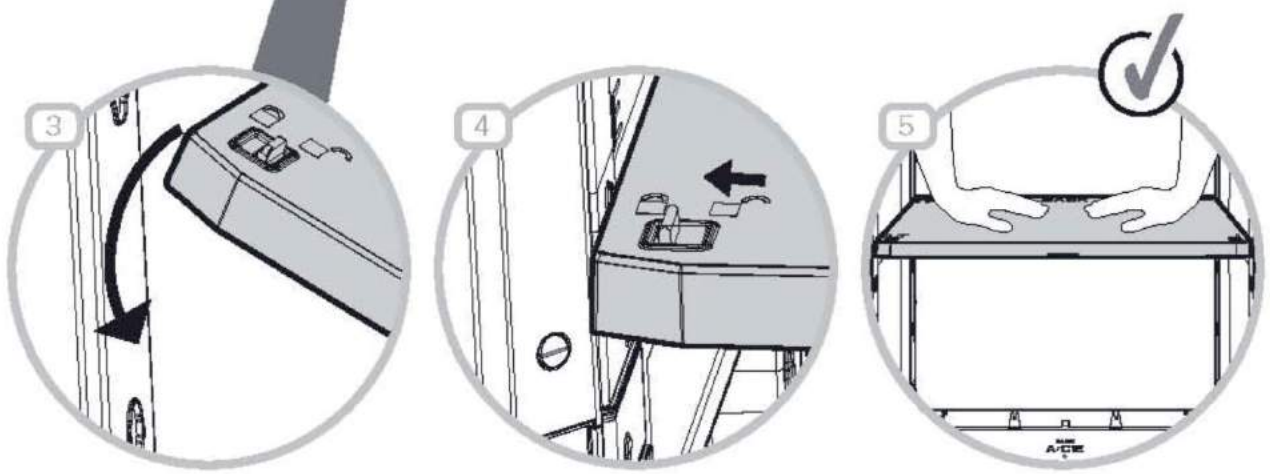
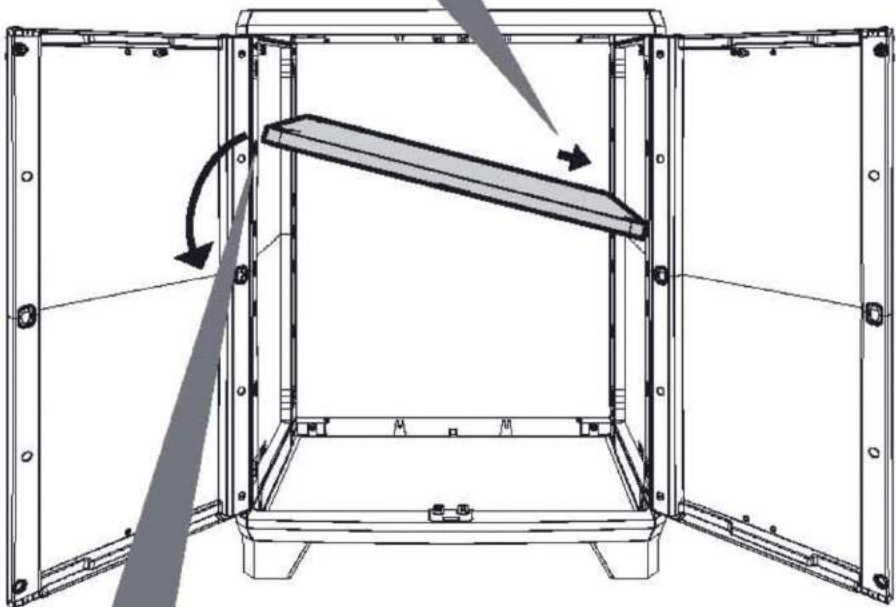
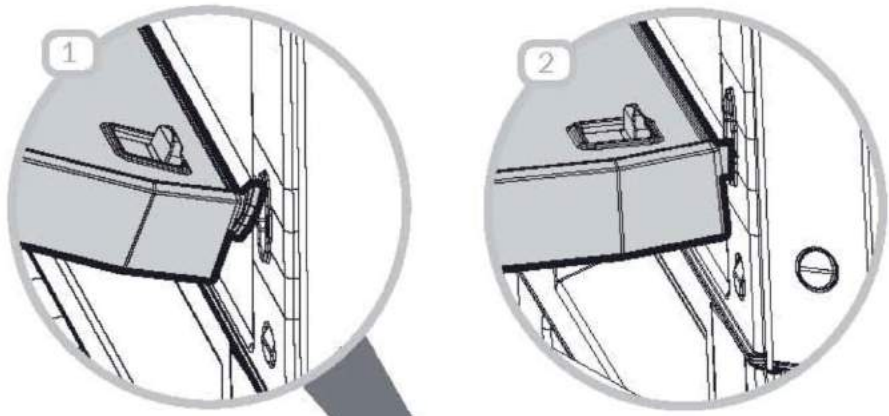

4x [4,2x22 mm]



2x

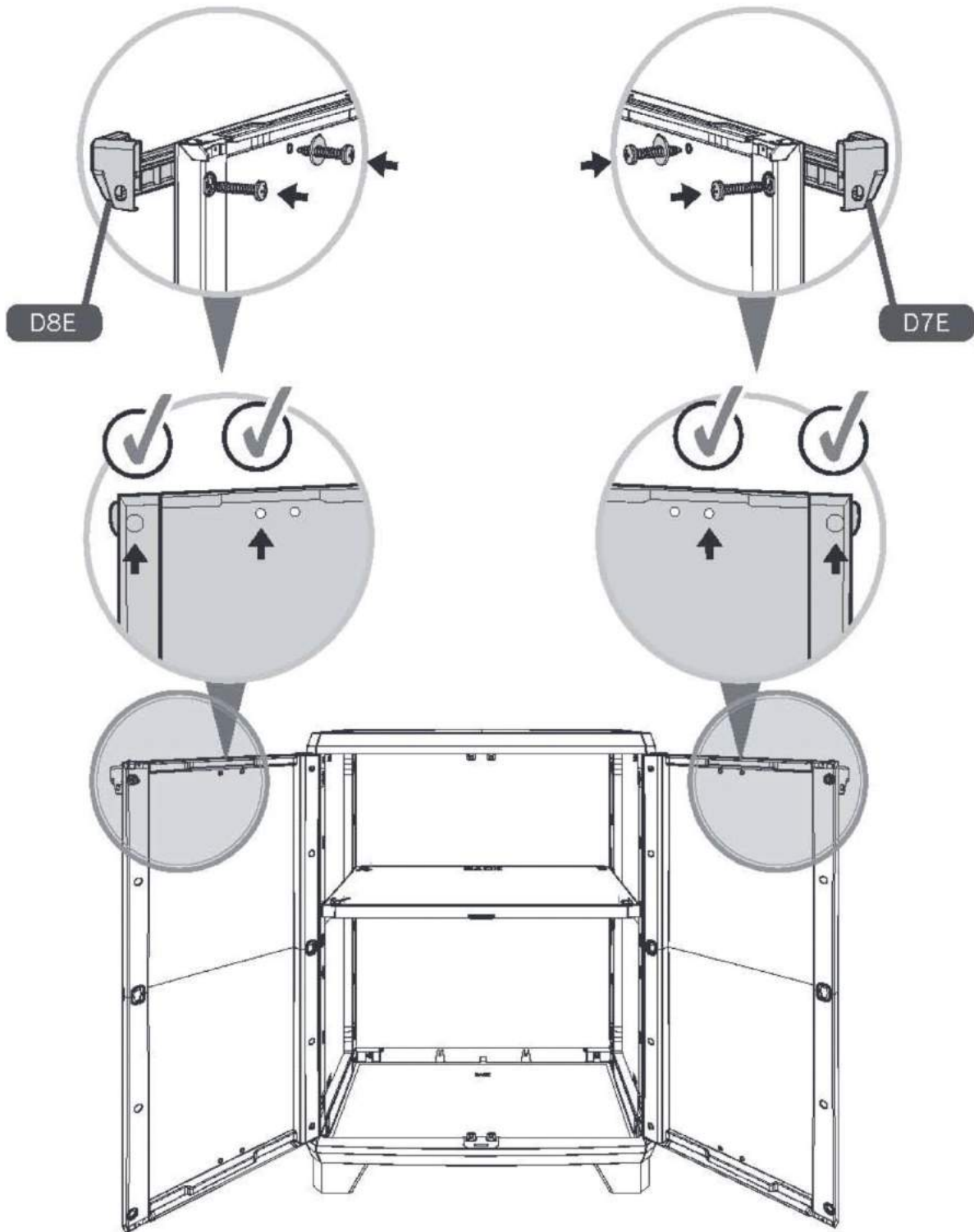

IT Per garantire maggiore stabilità dell'armadio su superfici irregolari, utilizzare le viti di regolazione poste sotto i piedi anteriori.
 CS For optimum stability on uneven surfaces, regulate the cupboard using the screws under the front feet.
 DE Um dem Schrank auf unebenen Flächen mehr Stabilität zu verleihen, verwenden Sie bitte die Stellschrauben unter den vorderen Füßen.
 FR Pour garantir une meilleure stabilité de l'armoire sur des surfaces irrégulières, utiliser les vis de réglage placées sous les pieds avant.
 ES Utilice los tornillos de regulación (situados bajo los pies delanteros) para asegurar una mayor estabilidad del armario.
 NL Gebruik de stelschroeven onder de voorpoten om een betere stabiliteit van de kast op onregelmatige vloeren te verzekeren.
 TR Dolabın düzgün olmayan yüzeyler üzerinde daha sağlam bir şekilde durmasını sağlamak için ön ayakların altındaki ayar vidalarını kullanın.
 GR Για να εξασφαλίσετε τη μεγαλύτερη σταθερότητα της ντουλάπας πάνω σε ανώμαλες επιφάνειες, χρησιμοποιήστε τις βίδες ρύθμισης που βρίσκονται κάτω από τα μπροστινά πόδια.
 RU Для того, чтобы обеспечить наибольшую устойчивость шкафа на неровной поверхности, воспользуйтесь регулировочными винтами, расположенными под передними ножками.
 RO Pentru a garanta o stabilitate mai mare a dulapului pe suprafețele neregulate, utilizați șuruburile de reglare aflate sub picioarele din față.
 CZ Abyste zajistili co největší stabilitu skříně na nerovném povrchu, použijte regulační šrouby umístěné pod předními nožičkami.
 PL Aby zagwarantować większą stabilność szafy, w przypadku nieregularnego podłoża, należy użyć śrub regulacyjnych, znajdujących się pod przednimi nóżkami.
 PT Para garantir maior estabilidade do armário sobre superfícies irregulares, utilize os parafusos de regulação situados em baixo dos pés dianteiros.

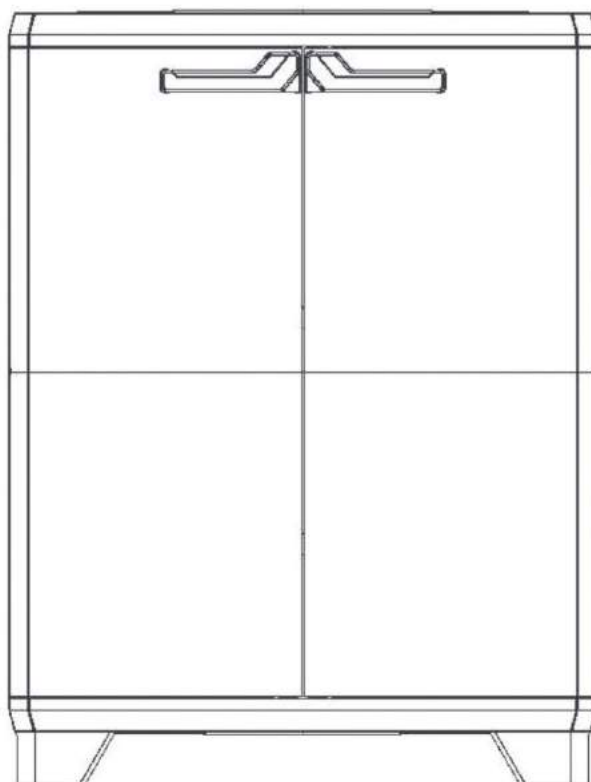

IT Fissare l'armadio a muro (viti e tasselli non inclusi). Scegliere il tassello in base alla superficie di appoggio. **GB** Fasten the cupboard to the wall (screws and anchors not included). Choose the anchor according to the surface. **DE** Befestigen Sie den Schrank an der Wand (Schrauben und Dübel sind nicht im Lieferumfang enthalten). Den Dübel je nach Stellfläche wählen. **FR** Fixer l'armoire au mur (vis et chevilles non incluses). Choisir la cheville en fonction de la surface d'appui. **ES** Fije el armario en la pared (la dotación no incluye tornillos y tacos). Elija el taco en función de la superficie de apoyo. **NL** Bevestig de kast aan de muur (schroeven en pluggen niet bijgeleverd). Kies de plug aan de hand van het steunoppervlak. **TR** Dolabı duvara sabitleyin (vidalar ve dübeller dahil değil). Destek yüzeyine göre dübel seçin. **GR** Στερεώστε την ντουλάπα στον τοίχο (βίδες και ούπα δεν περιλαμβάνονται). Επιλέξτε το ούπα ανάλογα με την επιφάνεια στήριξης. **RUS** Закрепите шкаф на стене (шурупы и дюбели не включены в поставку). Возьмите дюбель, пригодный для материала поверхности, у которой ставится шкаф. **RO** Fixați dulapul la perete (șuruburi și dibluri neincluse în dotare). Alegeți diblul în funcție de suprafața pe care urmează să se fixeze. **CZ** Připevněte skříň ke zdi (šrouby a hmoždinky nejsou součástí dodávky). Zvolte hmoždinku podle povrchu podkladu. **PL** Przymocować szafę do muru (śruby i kotki nie są zawarte w dostawie). Dobrać kotek w zależności od powierzchni oparcia. **PT** Fixe o armário na parede (parafusos e buchas não incluídos). Escolher a bucha conforme a superfície de apoio.

